



GMMC

*NFC integration needs ?  
- Stay relaxed and see what we can do for you*

## NFC Nutshell KIT for Development and Demonstration

SANGOMA-RFID Solutions

by GMMC GmbH V1.3

[www.gmmc-biz.com](http://www.gmmc-biz.com)

## Benefits & Features

- Development and demonstration tool for NFC/RFID based applications
- Featuring different modules which can be flexibly connected to support all types of applications and integration situations
- Micro sized modules to integrate into space constrained environment
- NFC Frontend,  $\mu$ C, adapter modules
- **Compatible with NXP development tools**
  - PEGODA / RFID Discover
  - NFC-Cockpit [link](#)
  - NFC Reader Library [link](#)
    - LPC1769 [link](#)
    - LPC11u68 [link](#)
    - PN7462 [link](#)
    - PN5180
    - CLRC663 plus family

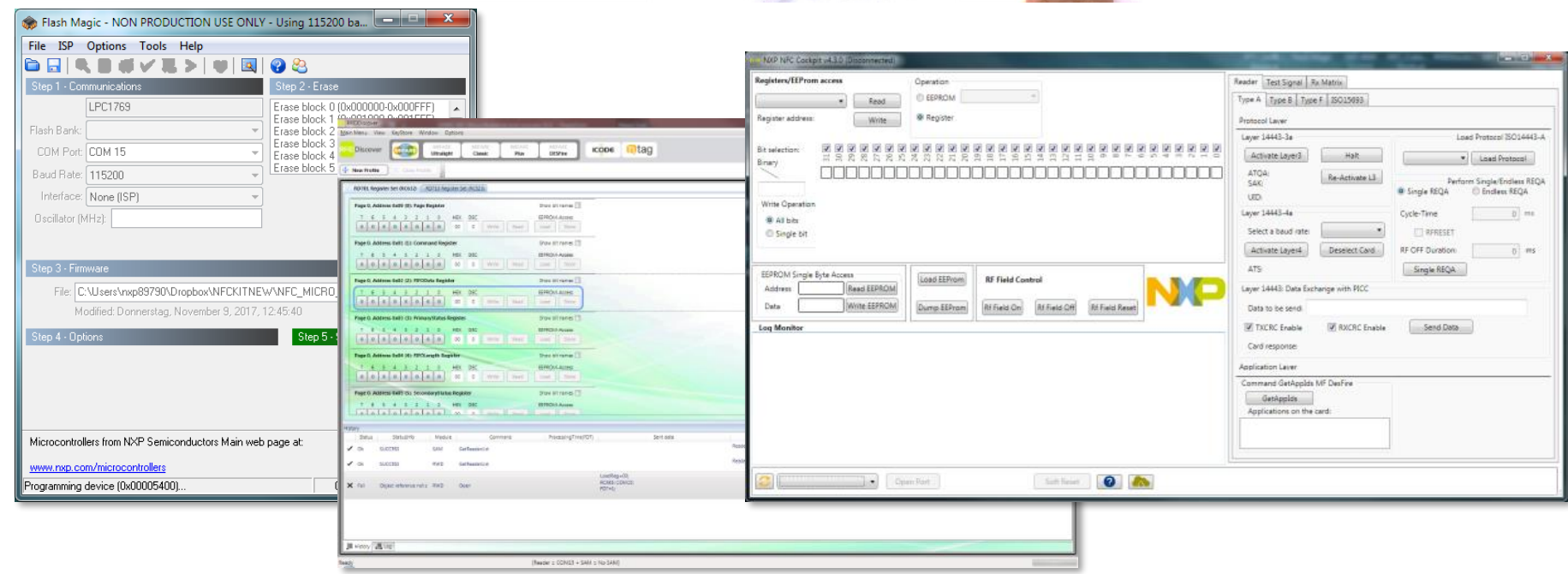
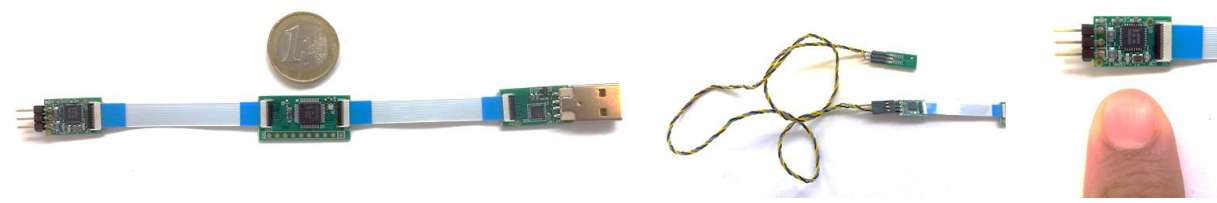

# OVERVIEW II



- Modules are connected via 14 pin FFC cables
  - Easy to combine different modules for specific applications
  - Zero power insertion
  - Space saving connector design



- Carefully open the lid with e.g. a flat screw driver. **Do not apply force !**

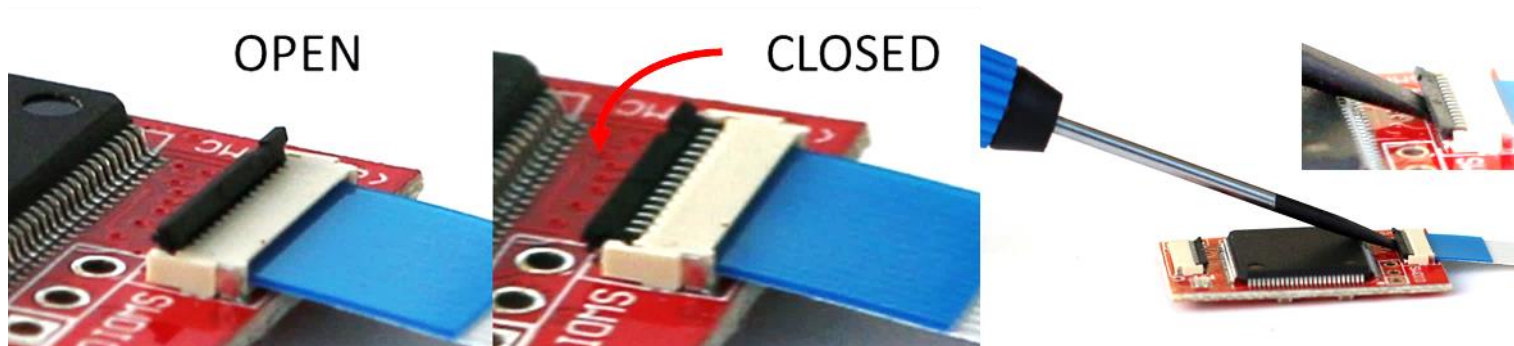

# OVERVIEW II

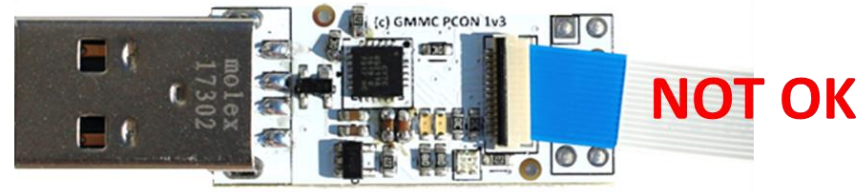
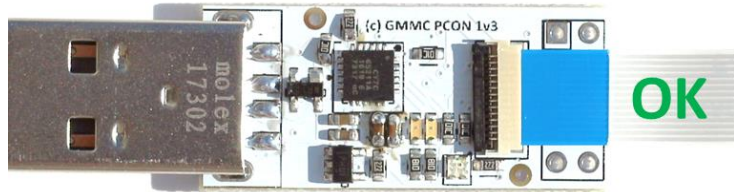
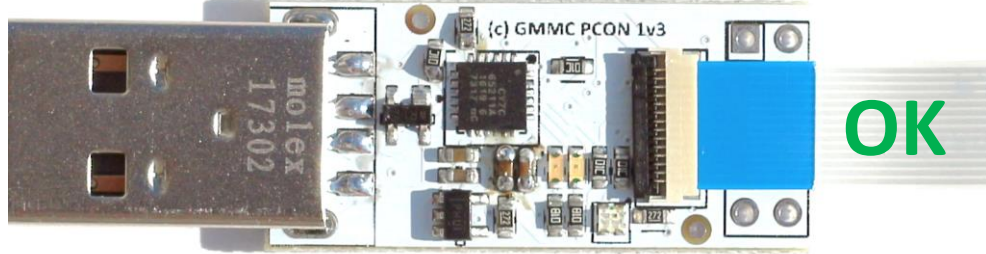

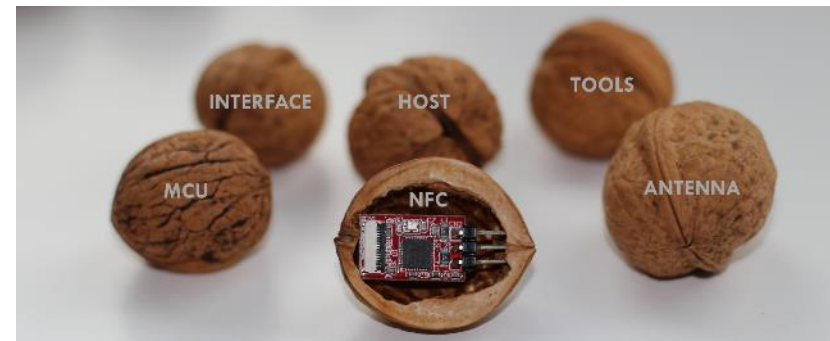

## Host Interface

- **USB Plug\***
- **Programmable converter**
- USB to
  - UART
  - I2C
  - SPI
- **Signal Debug Extender**
  - For measurements and connection to existing embedded systems
- **Microcontroller (MCU)**
  - LPC11u68 (JBD48)
  - LPC1769

## RF-Frontend

- CLRC663, CLRC663 plus family
  - incl. SLRC610, MFRC630, MF RC631
- PN512 family (incl. MFRC522 and MFRC523)
- **PN7462 Customizable Full NFC MCU**
  - RF Frontend with integrated Cortex M0 MCU
- **Antennas**
  - 20x10 mm, 20x20 mm, 40x40 mm, 72x48 mm
  - Twisted wire connection between antenna and RF modules

# COMPONENTS & CONNECTION OPTIONS



**GIHIC**  
we deliver for your success

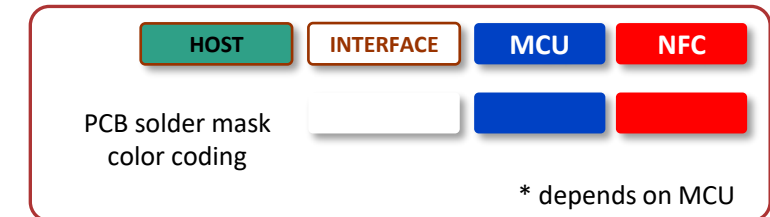
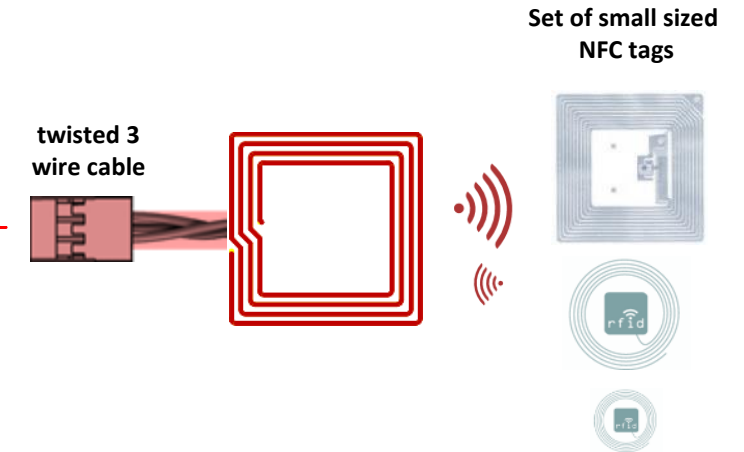
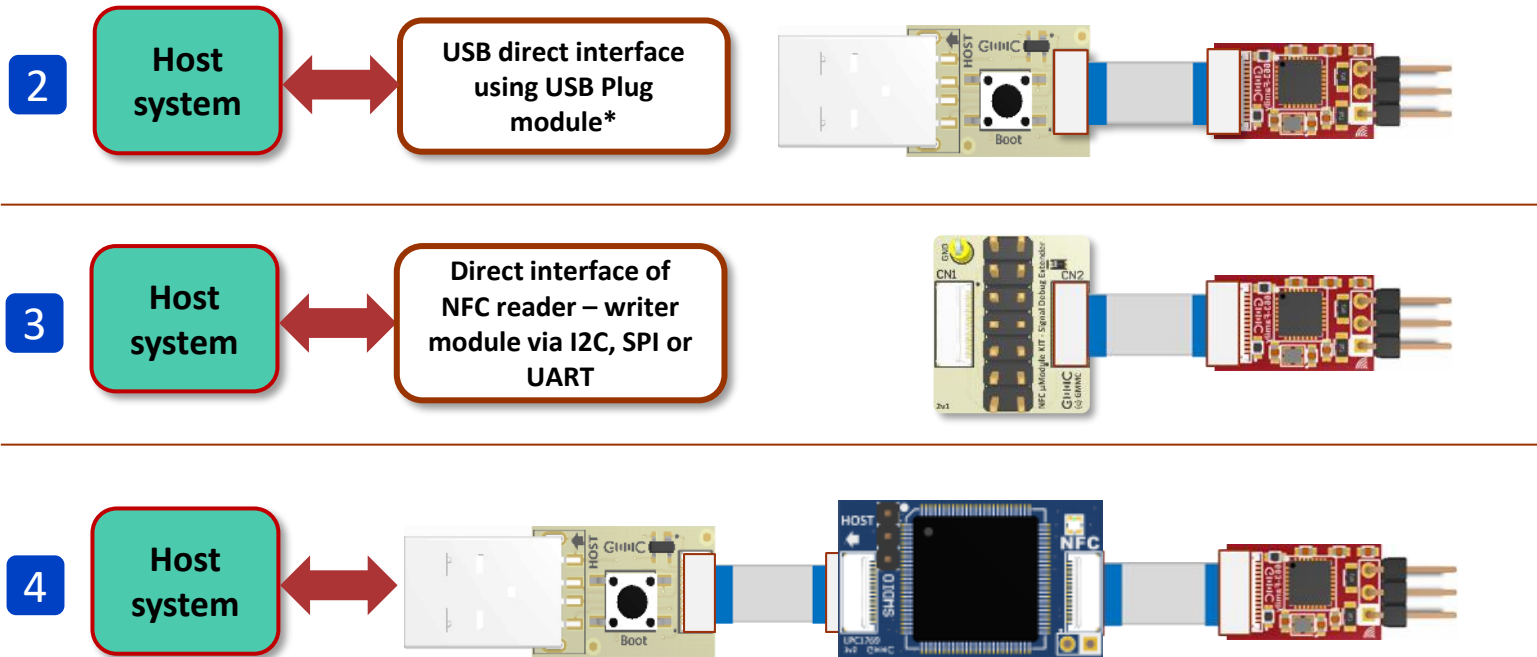
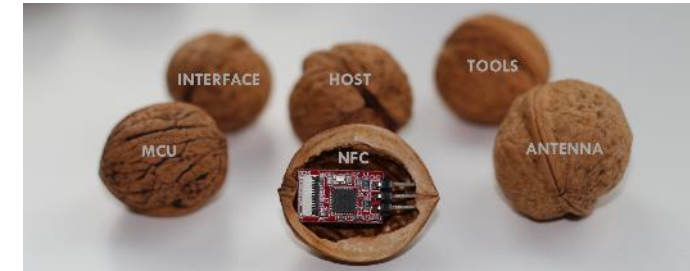
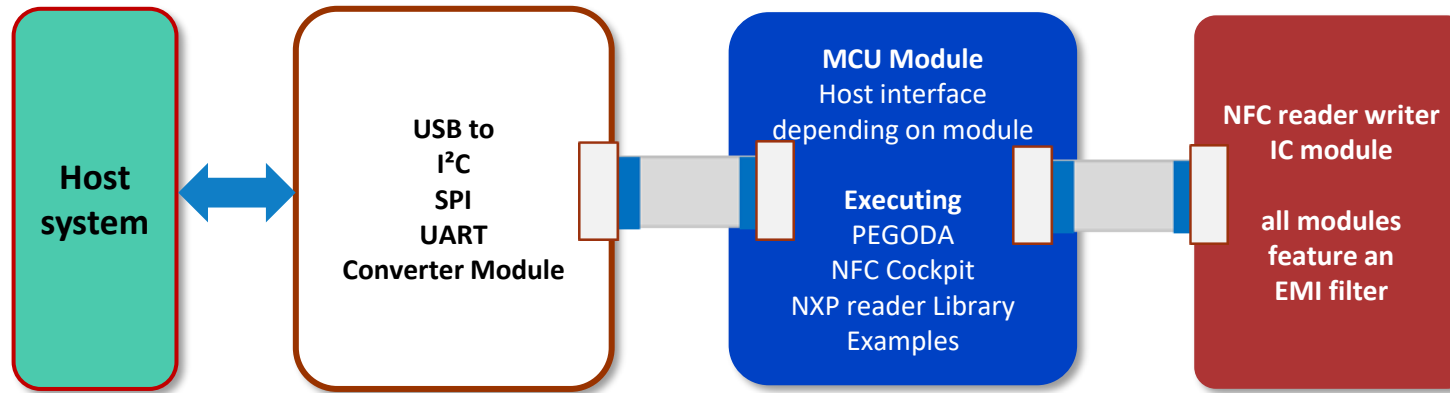

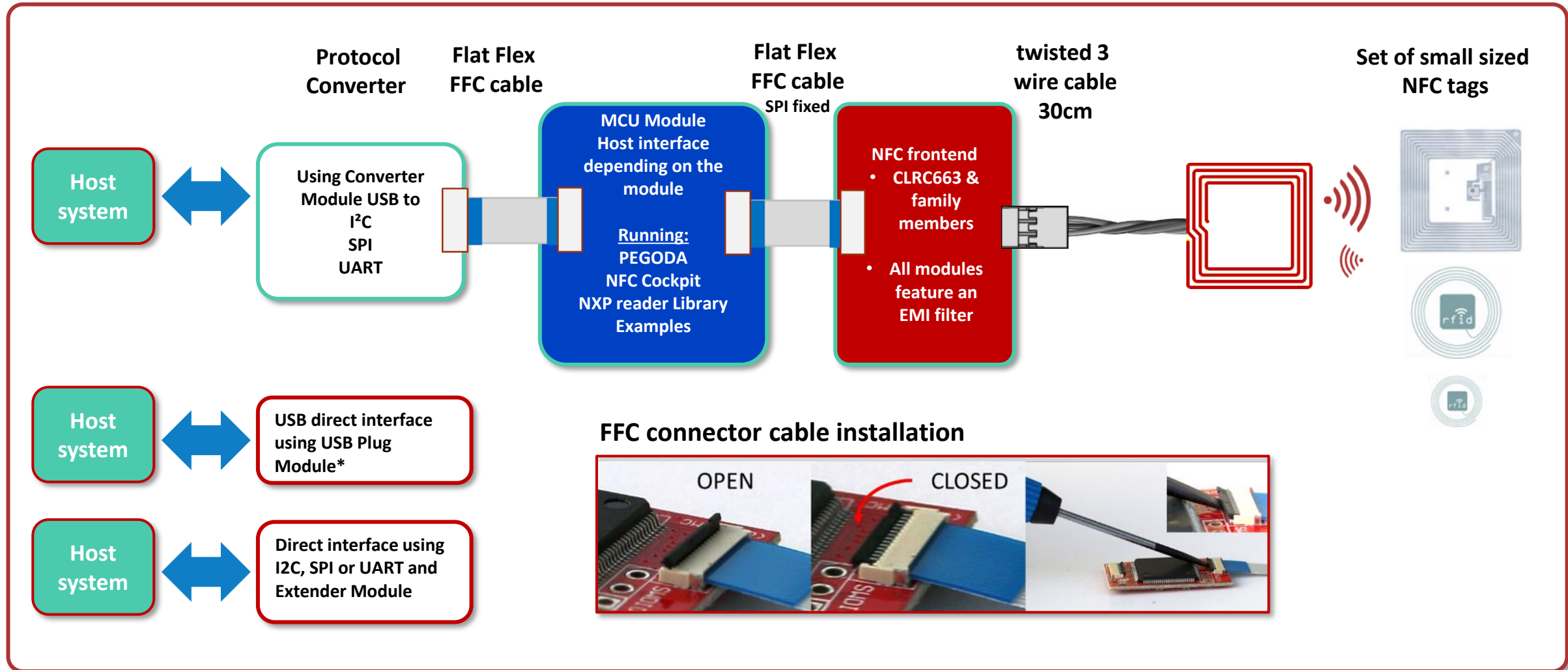
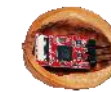

\* Not supported by all MCUs

# COMPONENTS & CONNECTION OPTIONS



**GMMIC**  
we deliver for your success

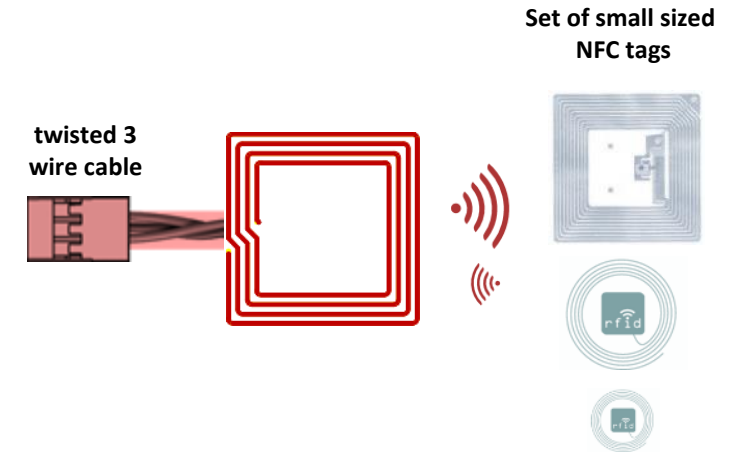
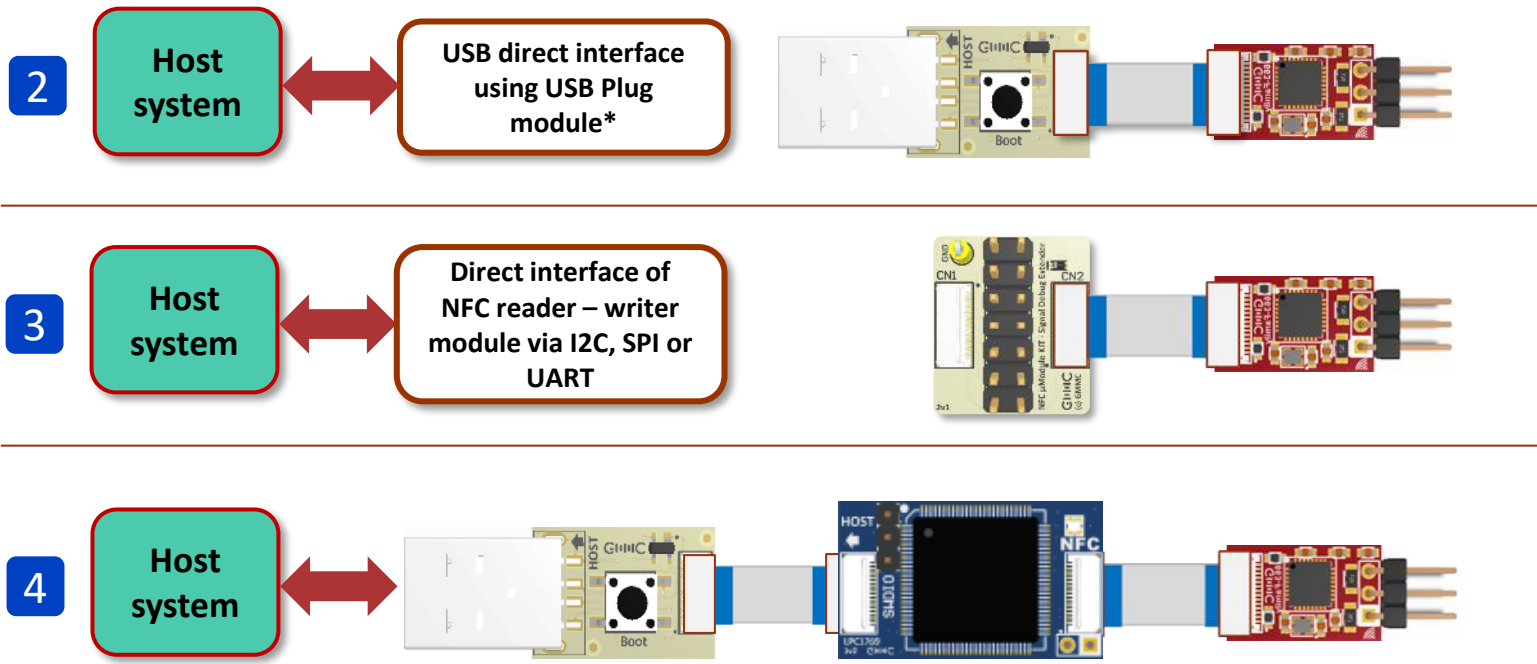
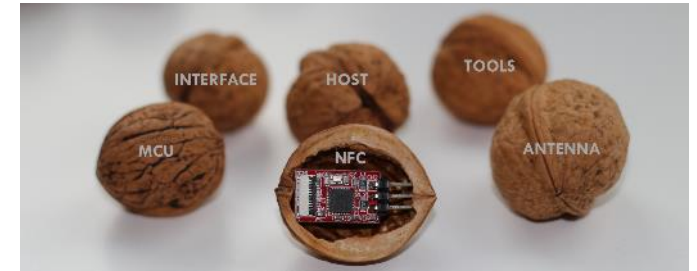
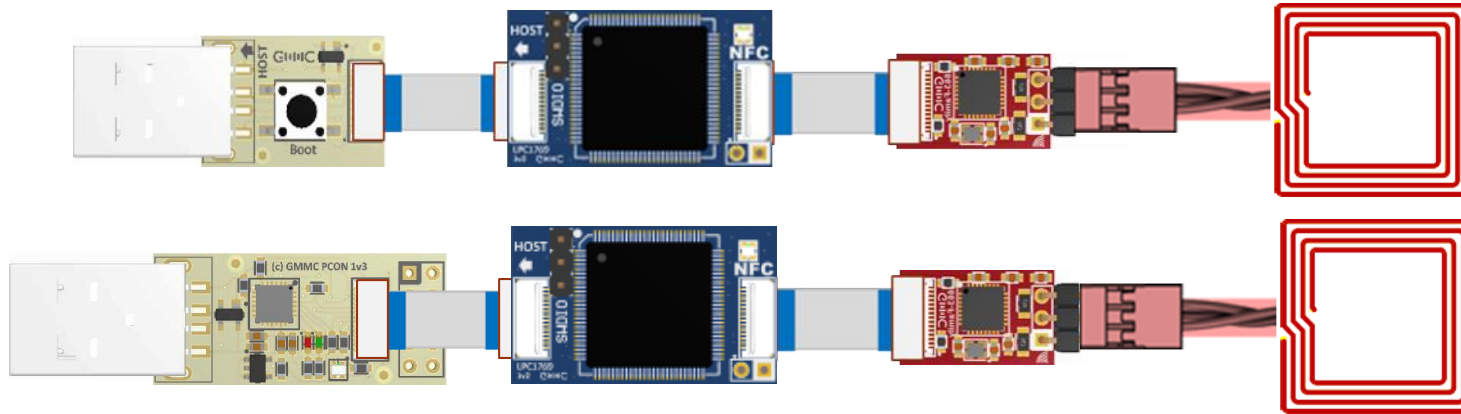

PCB solder mask color coding

HOST	INTERFACE	MCU	NFC

\* depends on MCU



# COMPONENTS & CONNECTION OPTIONS

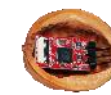

1

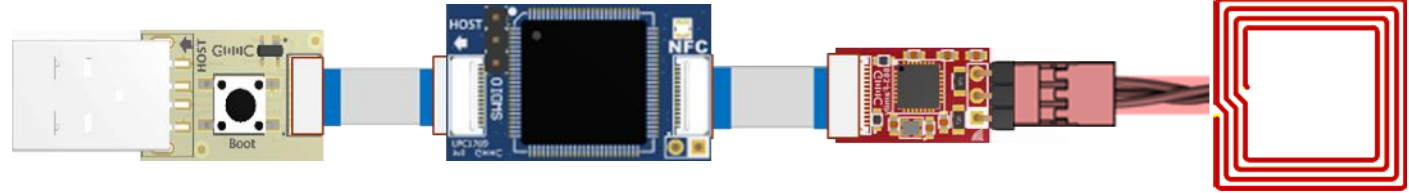

2

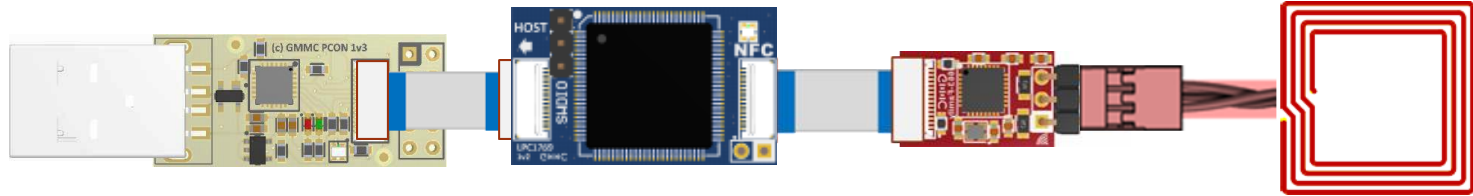

3

# COMPONENTS & CONNECTION OPTIONS

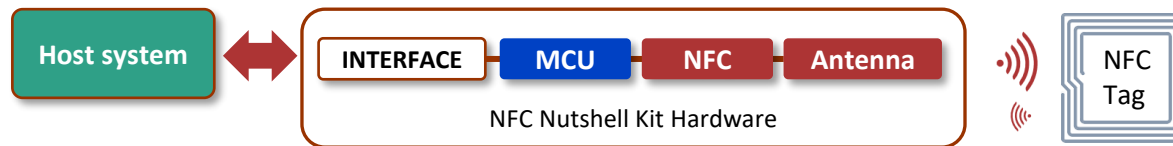
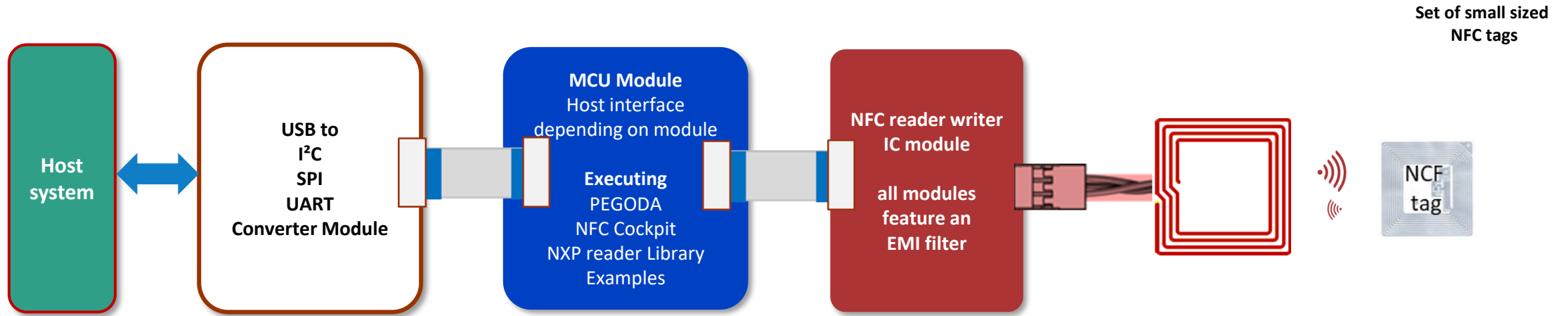

PCB solder mask color coding



\* Not supported by all MCUs

# MODULE HIGHLIGHTING ACTIVE



GIIIC  
we deliver for your success

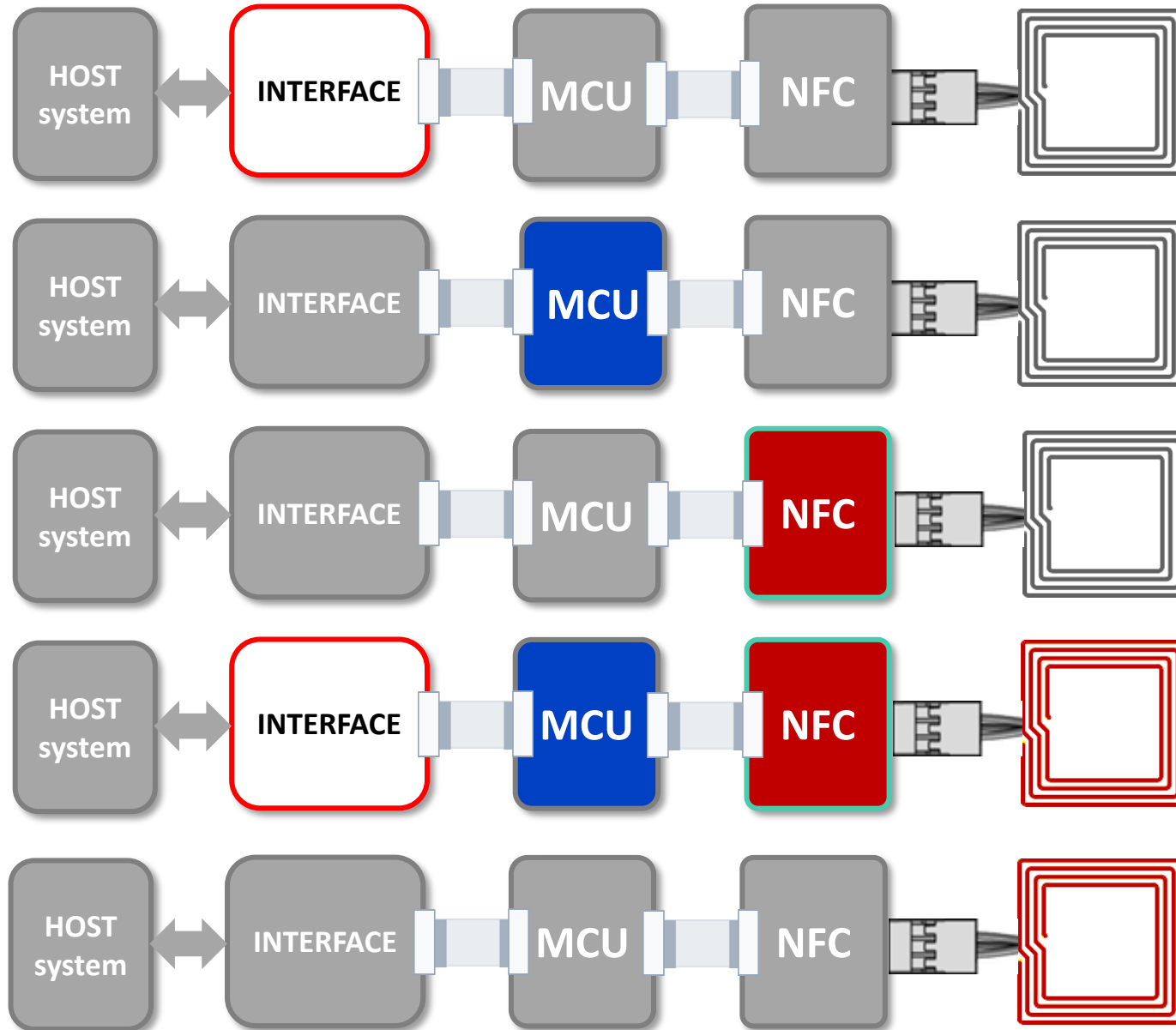

\* Not supported by all MCUs

# HOST INTERFACE MODULE OPTIONS



**GIIIC**  
we deliver for your success

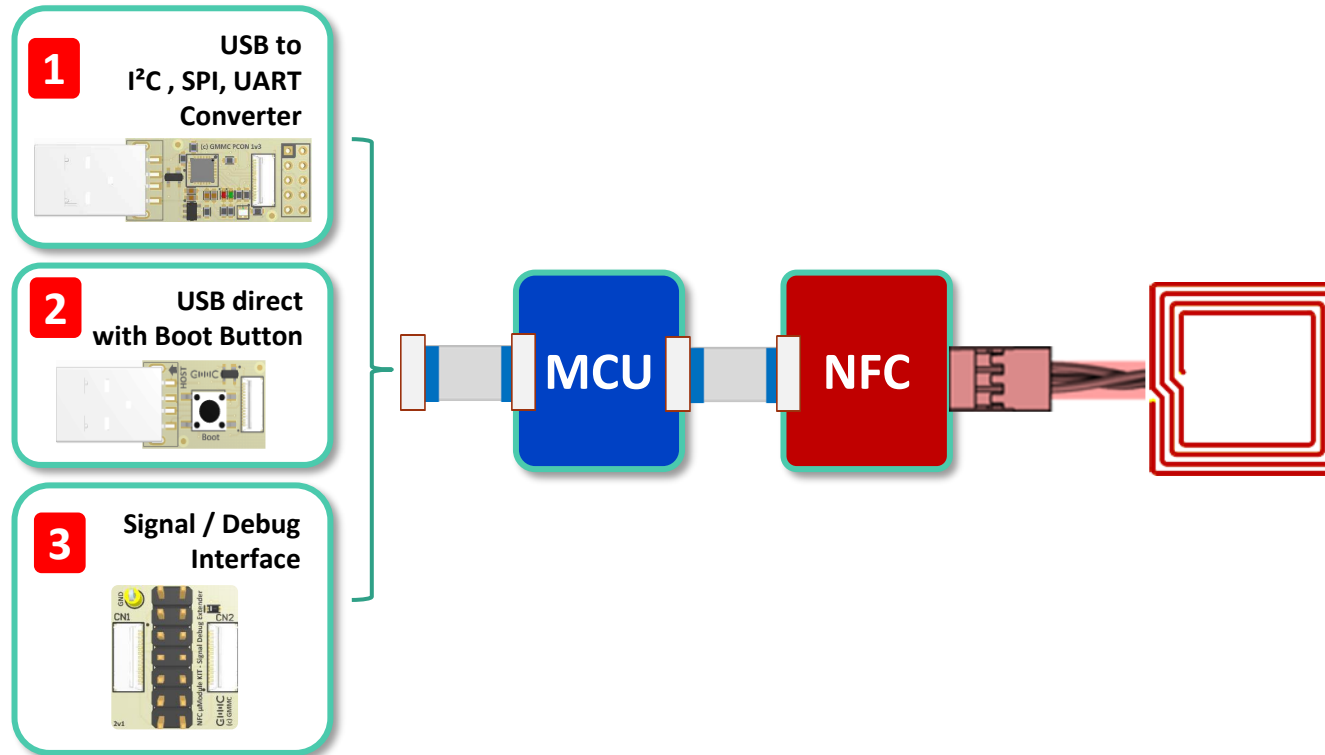

\* Not supported by all MCUs

# NFC MODULE OPTIONS



**GIIIC**  
we deliver for your success

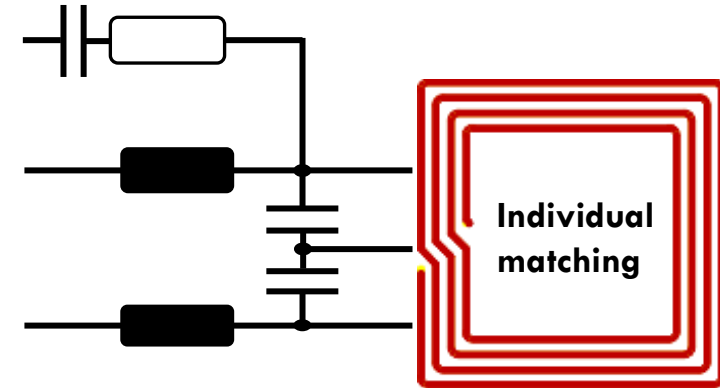
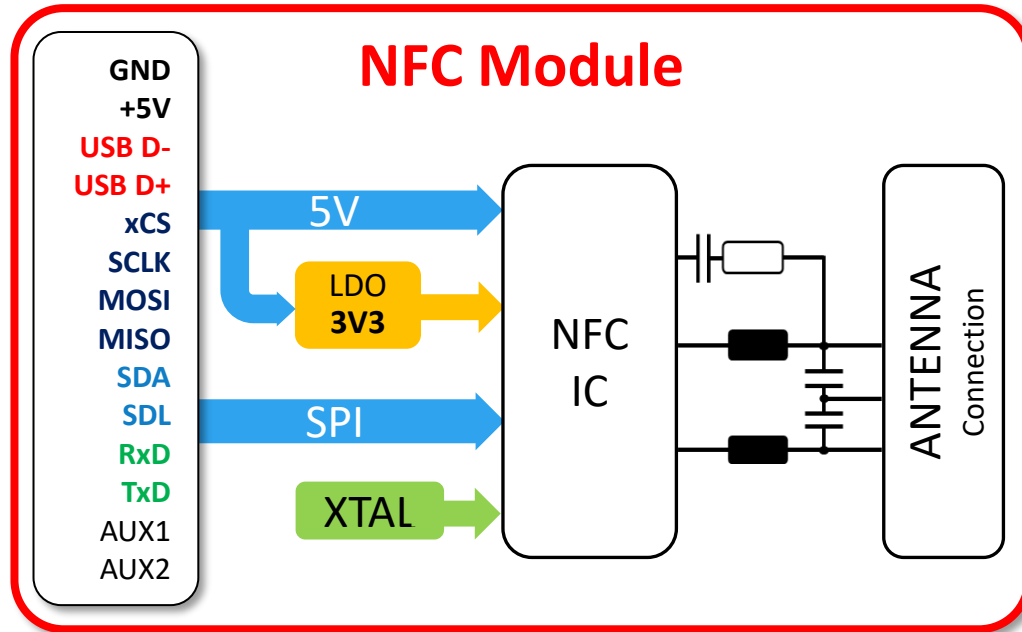

\* Not supported by all MCUs

# KIT CONFIGURATIONS

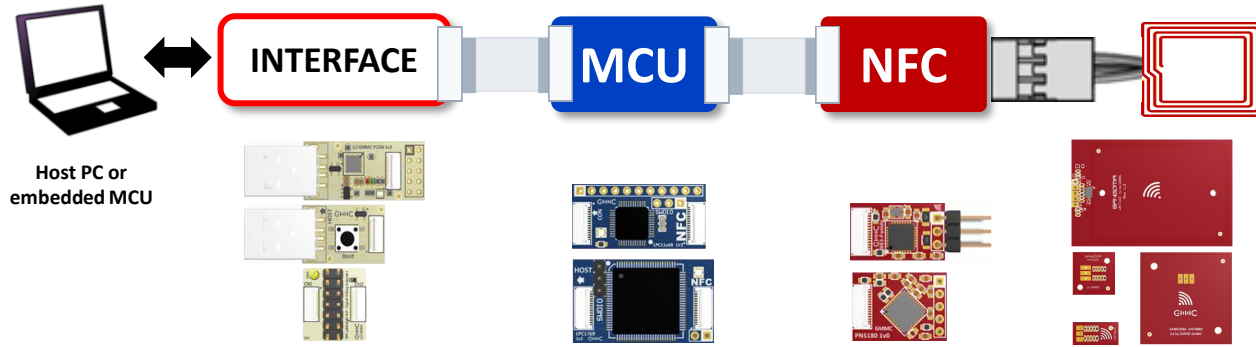



## Configuration: RFIDDiscover (pre-programmed)

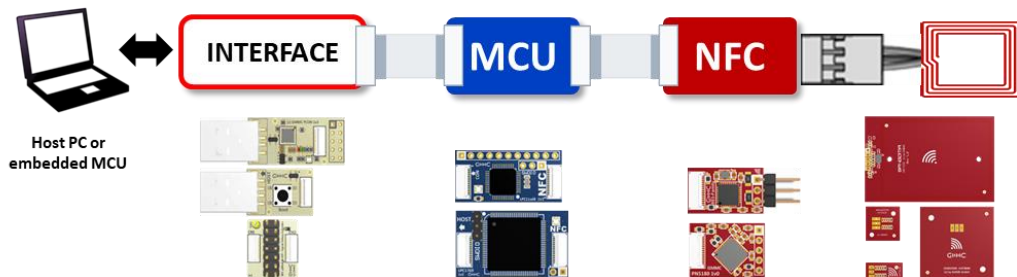

## Top view

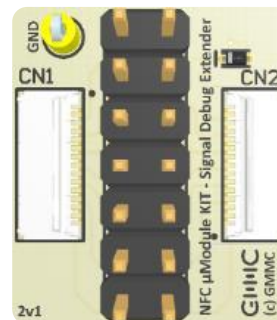

GND	5V
DM	DP
MOSI	SCKL
MISO	XSEL
SDA	SCL
TxD →	← RxD
AUX 1	AUX 2

## Configuration: RFIDDiscover (pre-programmed)



## Configuration: NFC Cockpit



## Connecting the Modules

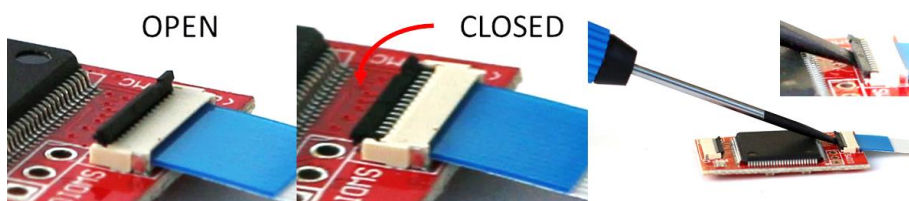

- Carefully open the lid with e.g. a flat screw driver or fingernail
- Slot in FFC cable straight – close the lid
- **Never apply force !**
- **Do not move while the Kit is powered!**

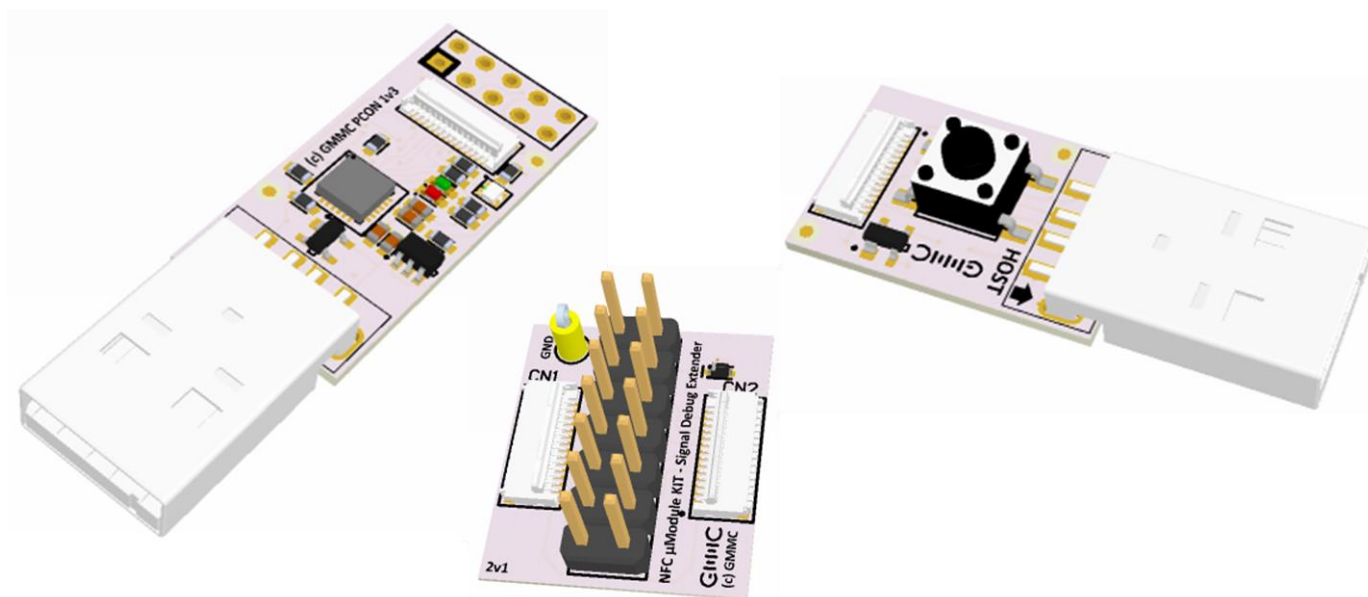

## Interface Modules



# HOST INTERFACE MODULES

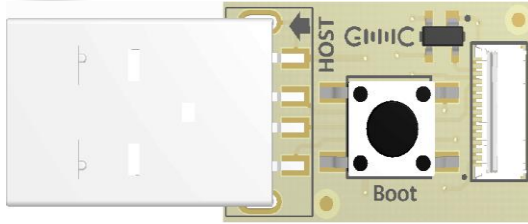

- **USB PLUG with bootloader button**
  - Supports USB Mass Storage Device Bootloader\*
    - Press and power-up for Bootloader mode

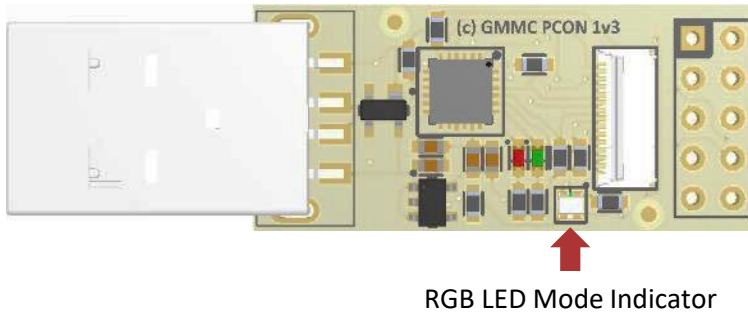

- **USB Converter**
  - Converts USB VCOM signals to I2C, SPI or UART
  - Protocol Converter Tool
    - for easy Protocol mode change
  - RGB LED color indicating the currently programmed interface mode
  - Supports MCU UART ISP Bootloader\*

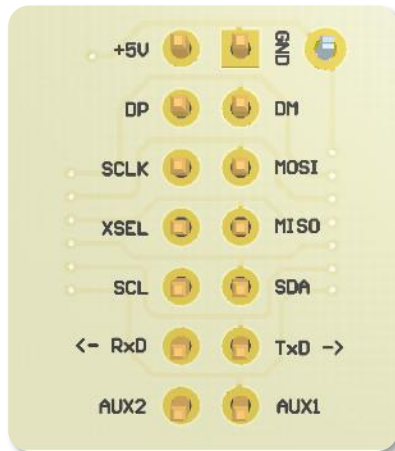
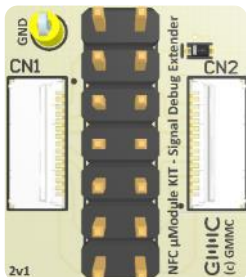

- **Signal debug / Interface extender Module**
  - Access to all signal pins
  - Allows to
    - connect to existing embedded host systems or
    - monitor signal lines
  - Ground test point for scope use.
  - Over voltage protection

\* Not supported by all MCUs

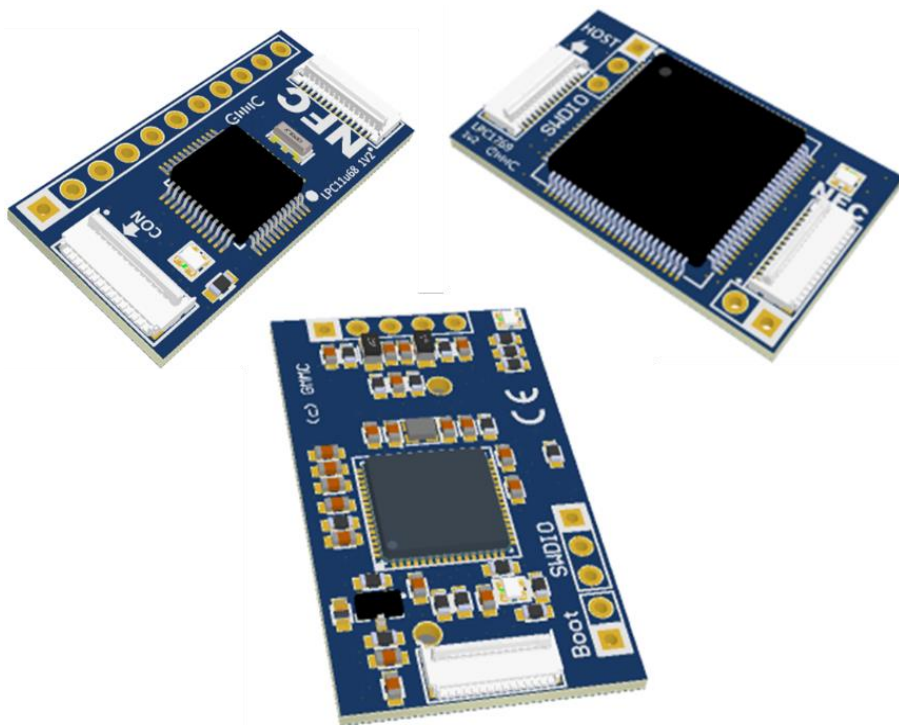

## MCU Modules

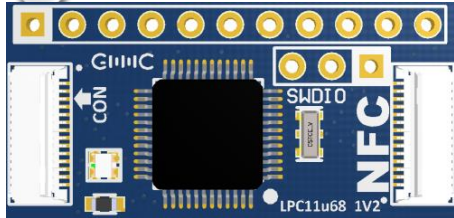

## LPC11U68 MICROCONTROLLER MODULE

- USB Mass Storage Bootloader
- USB, I2C, SPI and UART host interface support
- RGB Status LED
- SPI communication to RF frontend
- Expansion connector for peripheral hardware

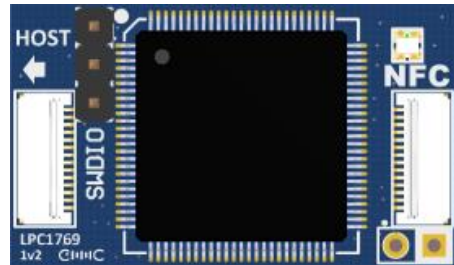

## LPC1769 Microcontroller Module

- USB Mass Storage Bootloader\*
- USB, I2C, SPI and UART host interface
- RGB status LED
- SPI communication to RF Frontend
- RFID Discover with PEGODA firmware
- NFC Cockpit firmware support using CLRC663 or its derivatives
  - *More NFC modules to be released*

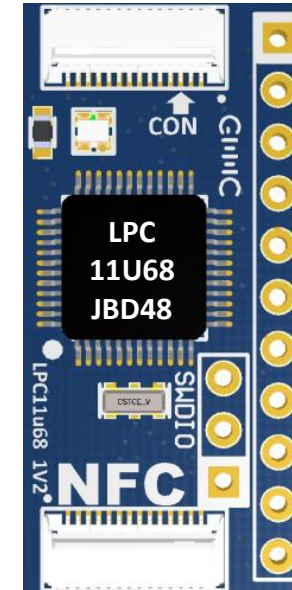

5V	
GND	
AUX 1	(PIO0_3)
AUX 2	(PIO0_1)
CPU_RxD	(PIO0_18)
CPU_TxD	(PIO0_19)
LDO_en	(PIO2_7)
xSEL	(PIO0_20)
MISO	(PIO0_8)
MOSI	(PIO0_9)
SCLK	(PIO0_6)

\* Requires preprogrammed USB Bootloader and specific user application

# MCU MODULES

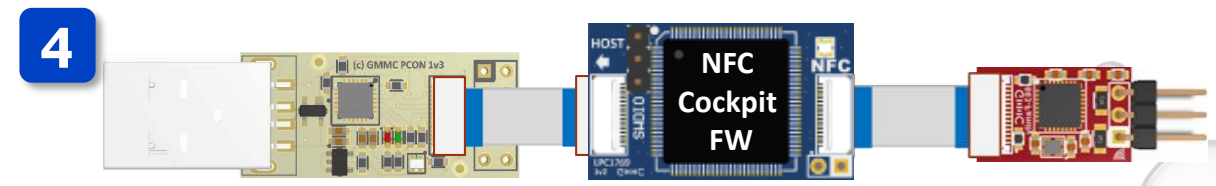
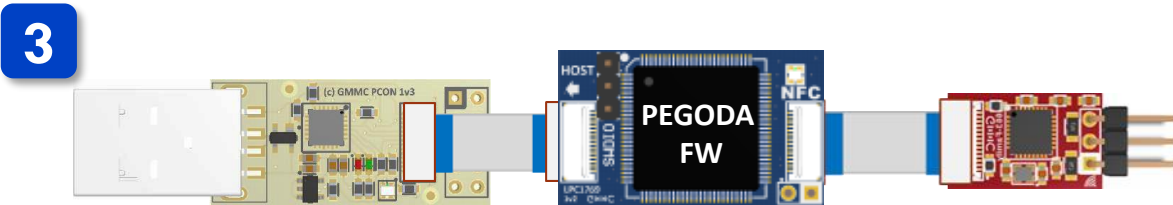
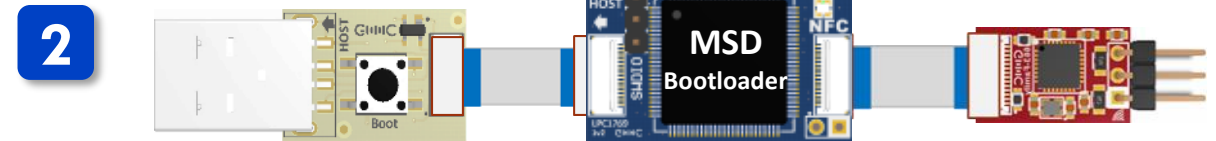
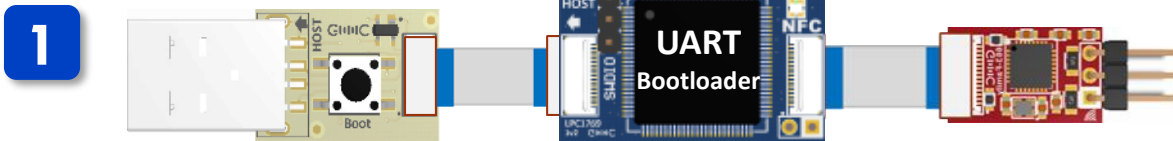
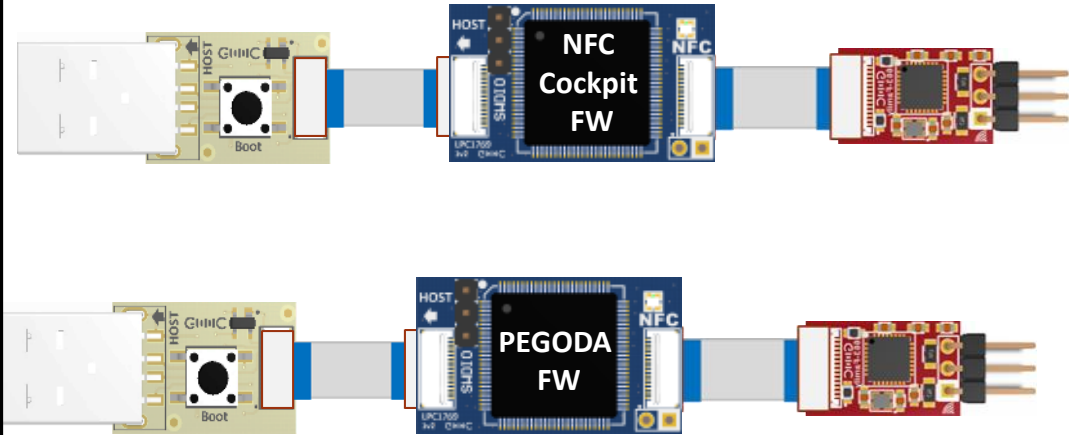
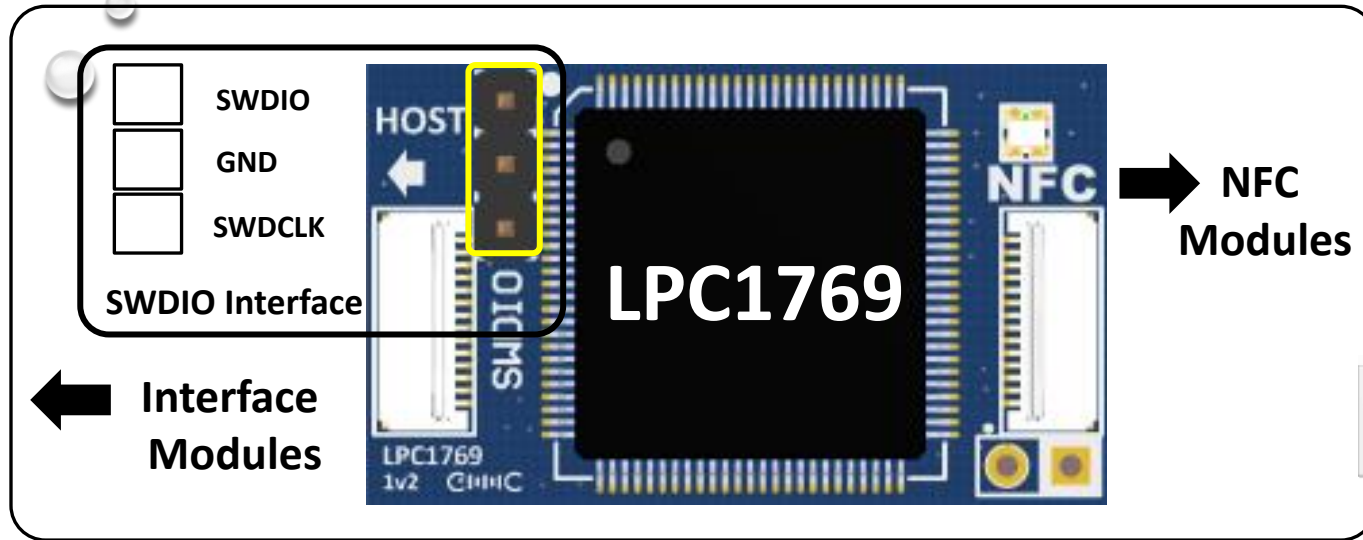

# MCU MODULES

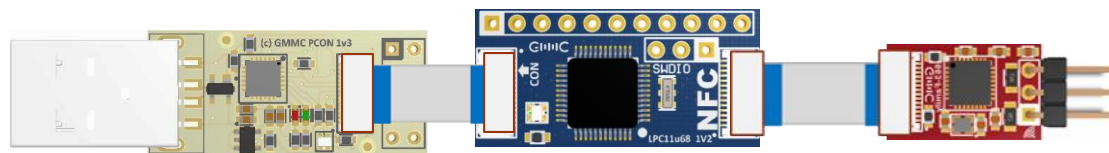
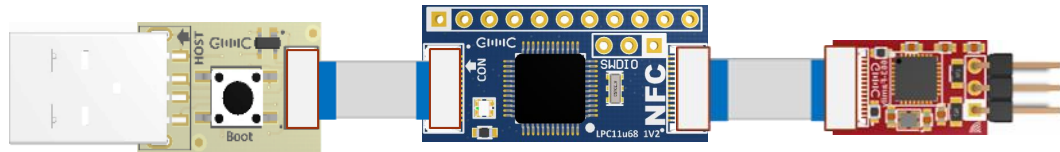
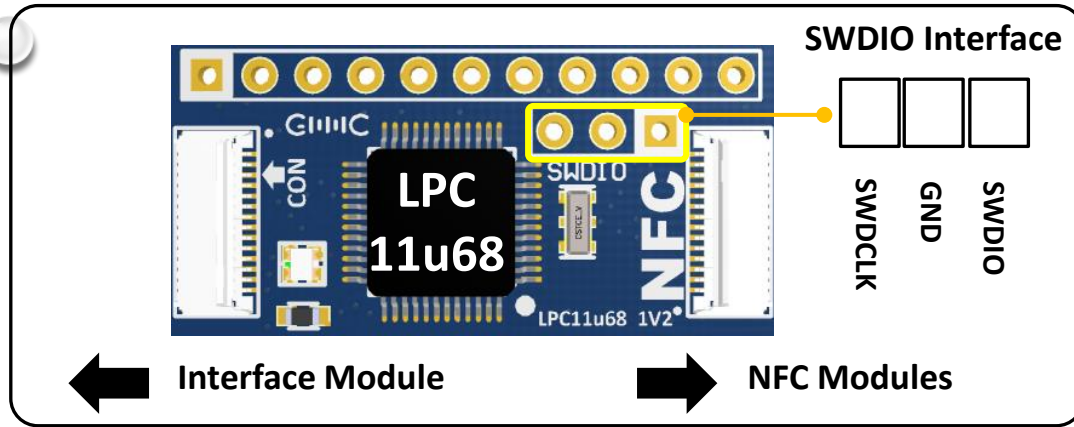

\* Requires preprogrammed USB Bootloader and specific user application

# MCU MODULE SWD-LPC LINK2 ADAPTER LPC 11U68

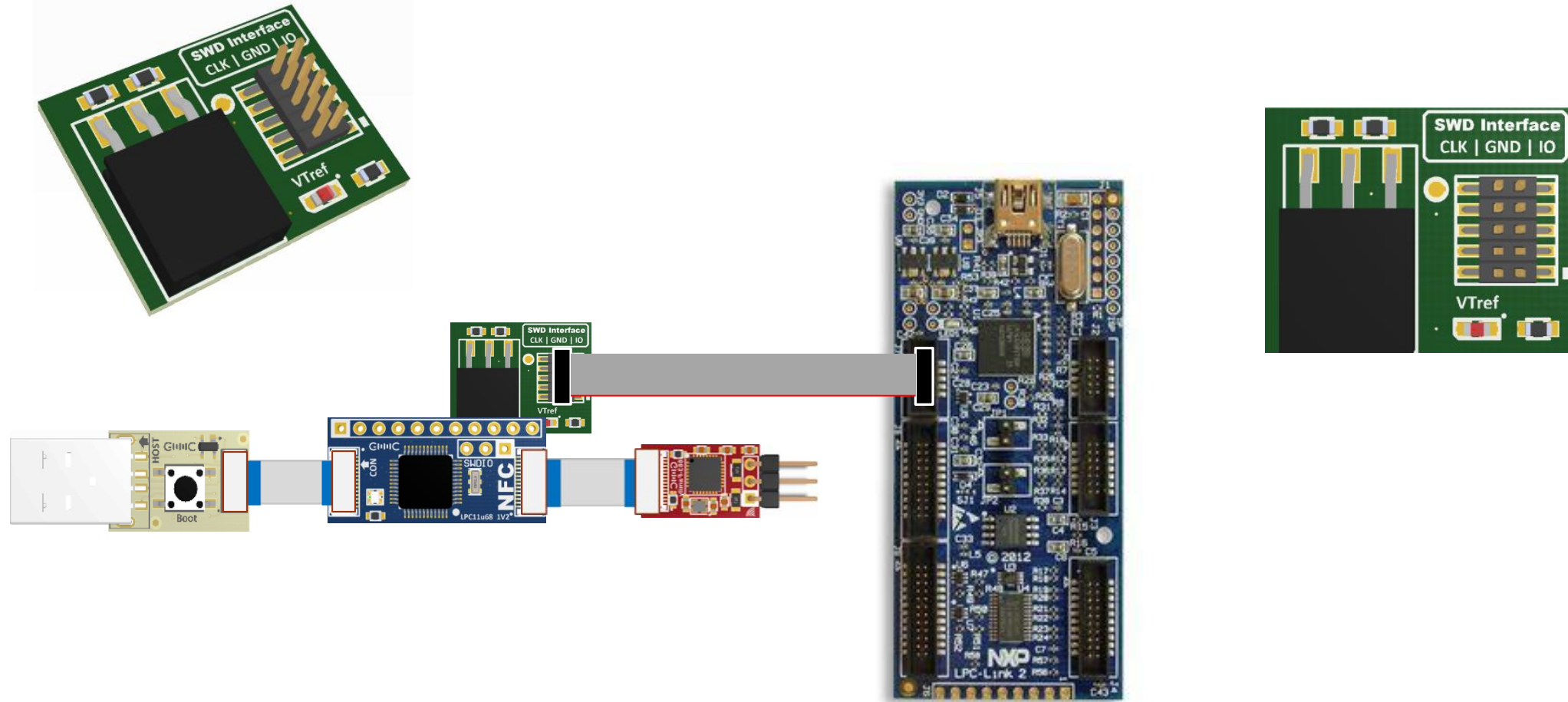

\* Requires preprogrammed USB Bootloader and specific user application

# MCU MODULE SWD-LPC LINK2 ADAPTER LPC 1769

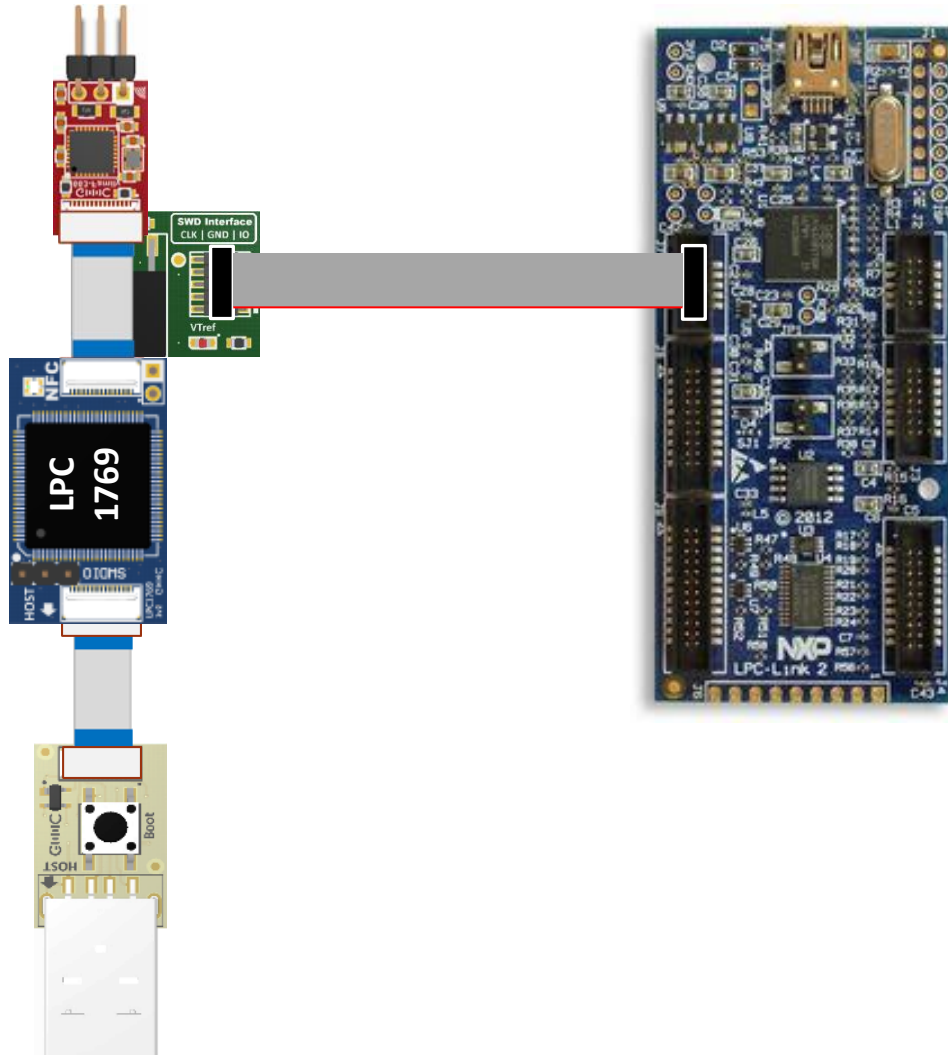

\* Requires preprogrammed USB Bootloader and specific user application

# MCU MODULE SWD-LPC LINK2 ADAPTER

## LPC 1769 AND LPC11U68

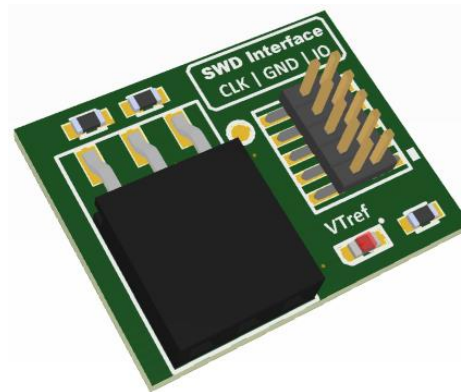
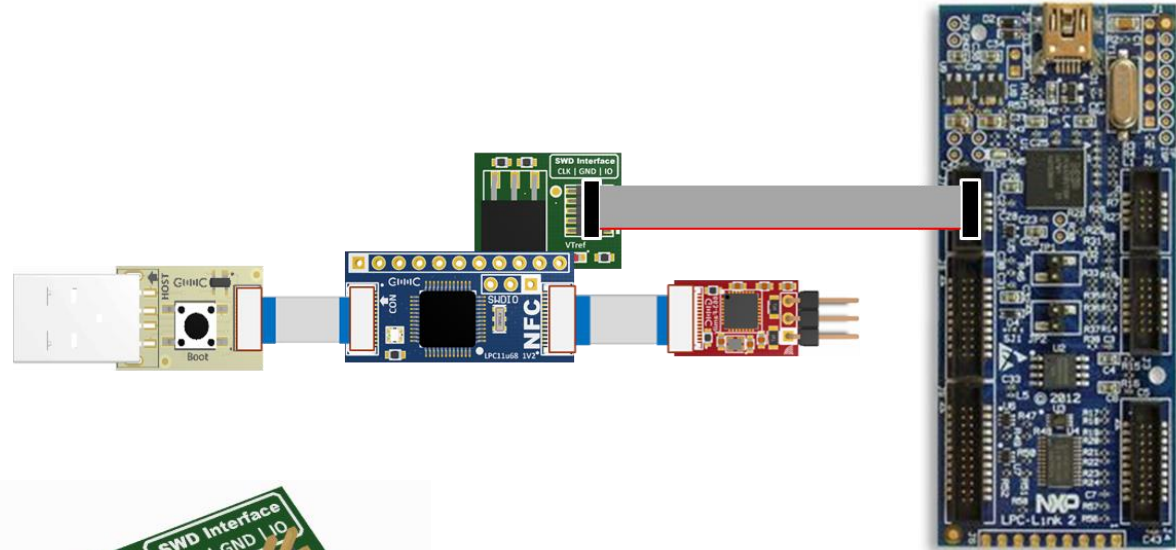
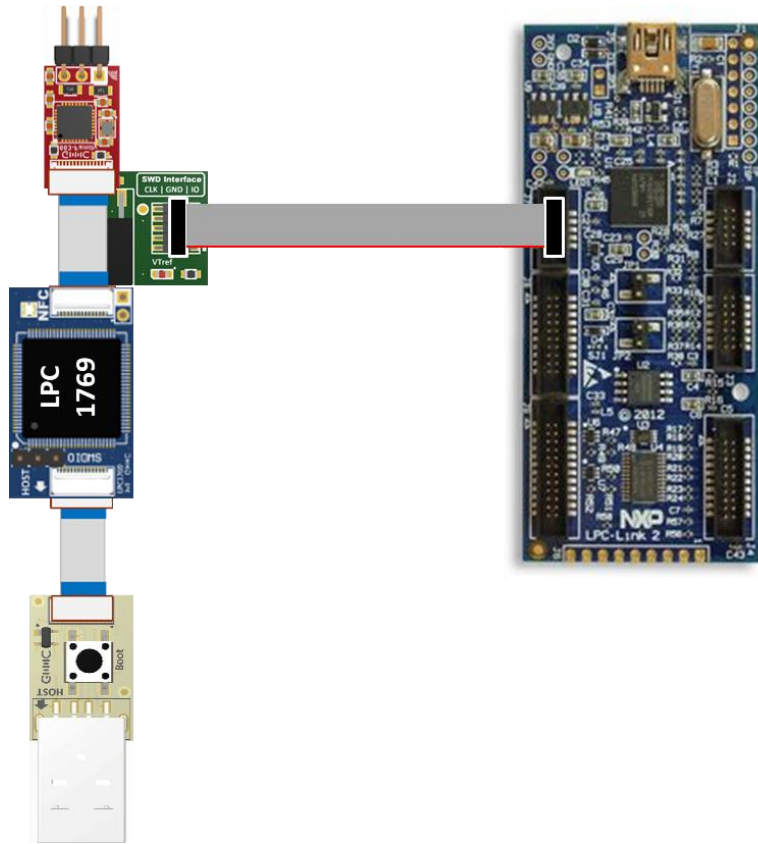

\* Requires preprogrammed USB Bootloader and specific user application



# MCU MODULES

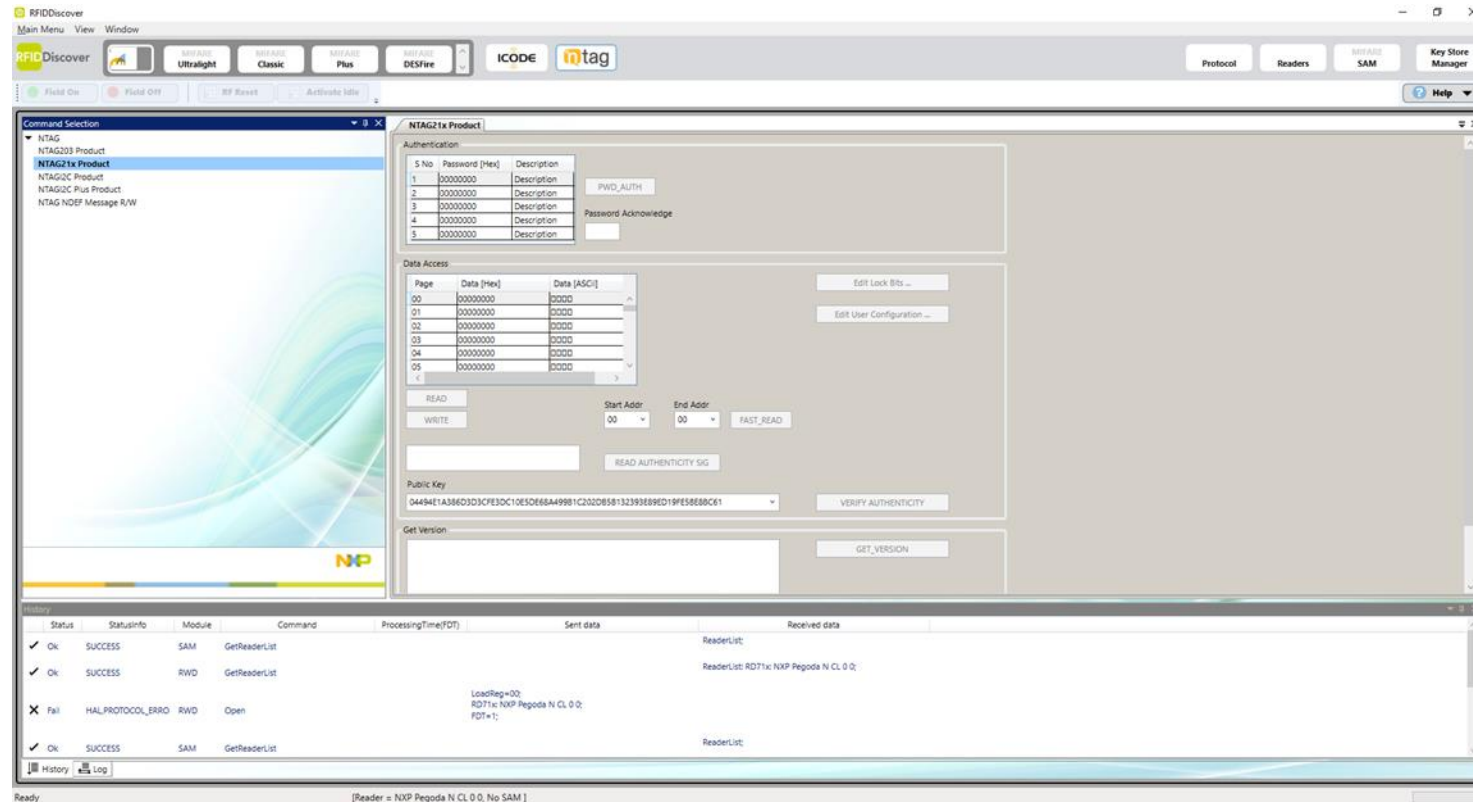

The screenshot displays the RFIDDiscover software interface. The main window is titled "NTAG21x Product" and contains several sections:

- Command Selection:** A list of commands including "NTAG", "NTAG21x Product", "NTAG2C Product", "NTAG2C Plus Product", and "NTAG NDEF Message R/W".
- Authentication:** A table with 5 rows, each containing a "S No", "Password (Hex)", and "Description". The descriptions include "PWD\_AUTH" and "Password Acknowledge".
- Data Access:** A table with 6 rows, each containing a "Page", "Data (Hex)", and "Data (ASCII)".
- READ/WRITE:** A section with "READ" and "WRITE" buttons, "Start Addr" and "End Addr" dropdowns, and a "FAST\_READ" button.
- Public Key:** A section with a "Public Key" dropdown and a "VERIFY AUTHENTICITY" button.
- Get Version:** A section with a "GET\_VERSION" button.

At the bottom, there is a "History" table with columns: Status, StatusInfo, Module, Command, ProcessingTime(FDT), Sent data, and Received data. The table shows several successful "GetReaderList" commands and one failed "Open" command.

Status	StatusInfo	Module	Command	ProcessingTime(FDT)	Sent data	Received data
✓ Ok	SUCCESS	SAM	GetReaderList			ReaderList:
✓ Ok	SUCCESS	RWD	GetReaderList			ReaderList: RD71x NXP Pegoda N CL 0 0;
✗ Fail	HAL_PROTOCOL_ERROR	RWD	Open		LoadReg=00; RD71x NXP Pegoda N CL 0 0; FDT=1;	
✓ Ok	SUCCESS	SAM	GetReaderList			ReaderList:

Ready [Reader = NXP Pegoda N CL 0 0, No SAM]

\* Requires preprogrammed USB Bootloader and specific user application

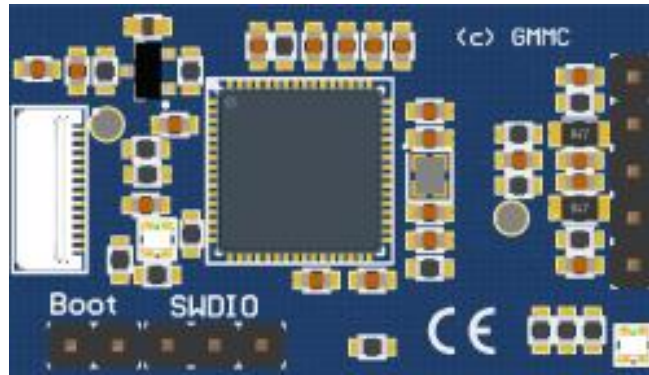

- **PN7462AU Module with SAM socket**

- USB, I2C, SPI and UART as HIF supporting USB mass storage bootloader
- Contact ISO7816 and Contactless (ISO14443/15693) interface
- 2 RGB LEDs
- NFC Cockpit firmware





# NFC Modules

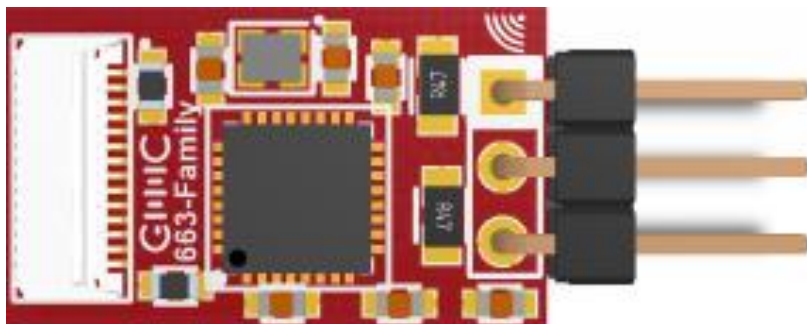

## CLRC663 NFC Frontend Module

- 18.5 x 11 mm
- SPI interface to  $\mu$ Controller
- can be operated with
  - NFC Cockpit firmware (with LPC1769  $\mu$ C module)
  - RFID discover – Pegoda Firmware (with LPC1769  $\mu$ C module)
  - MCU Expresso with Protocol converter module
  - ISO14443, ISO15693
  - Optional family members
    - MFRC630, MFRC631, SLRC610 and its plus versions

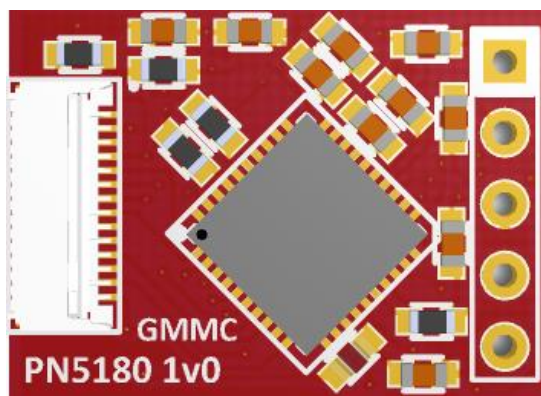

## PN5180 Full NFC Frontend

- 19 x 14 mm
- SPI interface to  $\mu$ Controller
- Can be operated with
  - NFC Cockpit firmware (with LPC1769  $\mu$ C module)
  - RFID discover – Pegoda Firmware (with LPC1769  $\mu$ C module)
  - MCU Expresso with Protocol converter module
  - ISO/IEC 14443, ISO/IEC15693, ISO/IEC18092

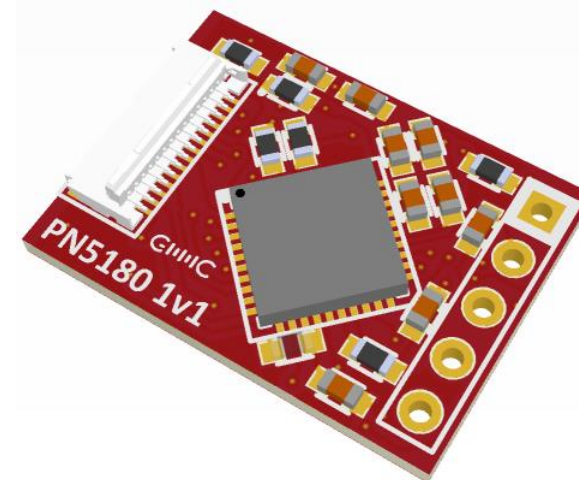
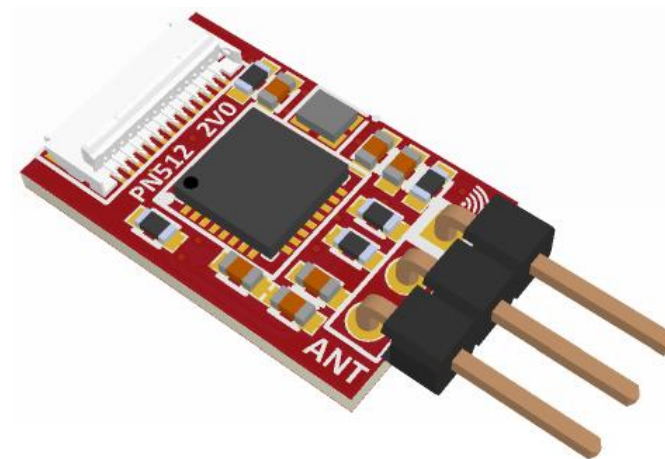
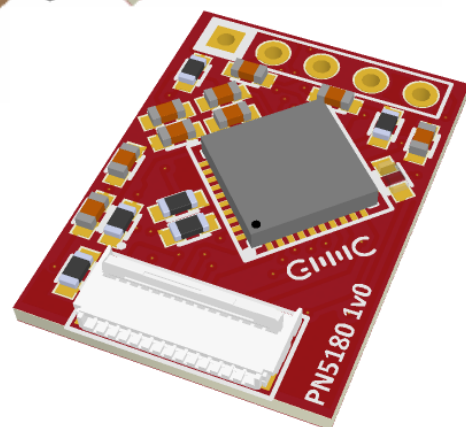
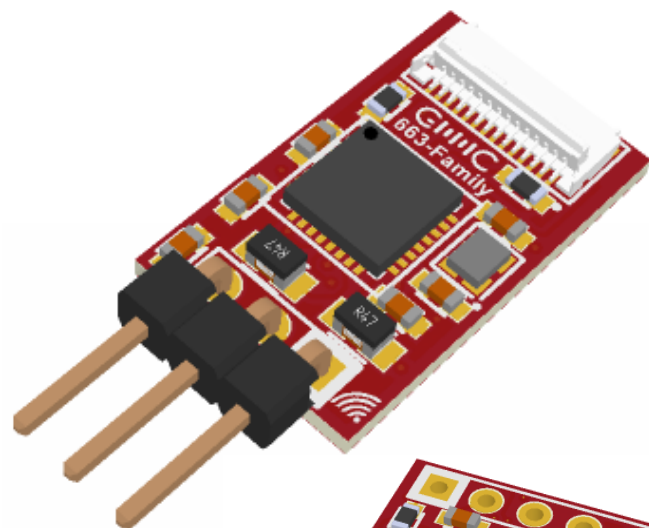
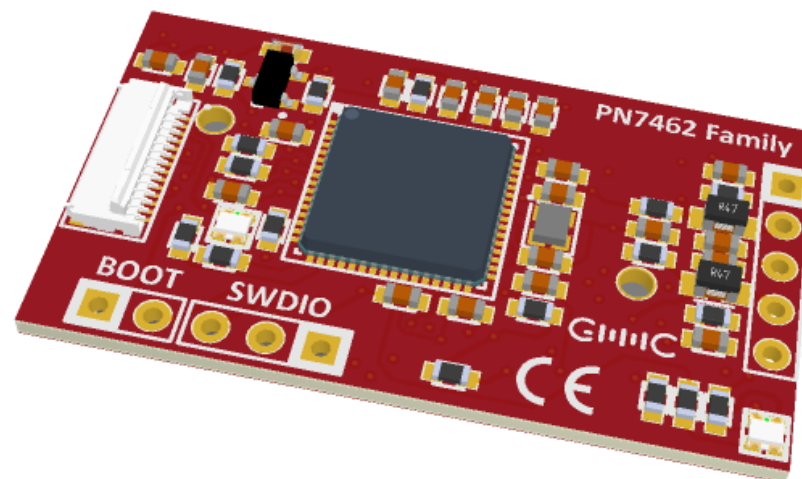
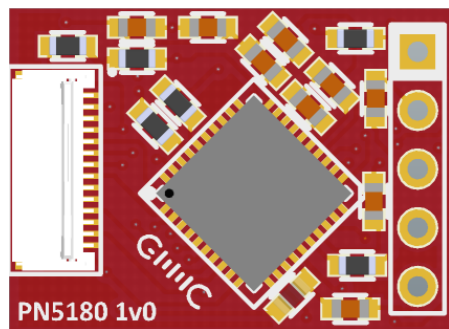



- **APPLICATION DEVELOPMENT on the PC**
  - C++ option of the NXP Reader Library with LPC/MCU Expresso
- **No MCU needed**
  - Application is executed on the PC directly communicating to RF Module
- **Extreme small overall form factor**

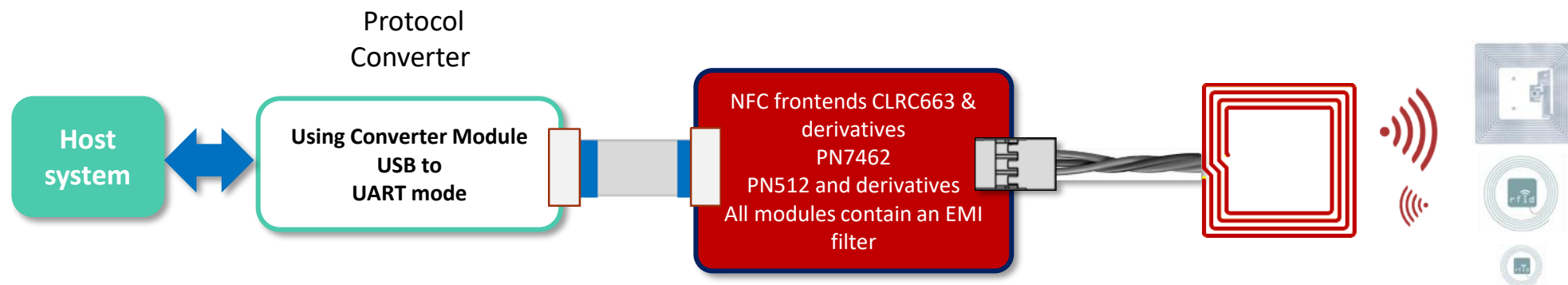

\* Not supported by all MCUs



# NFC Antennas

# 13.56MHZ ANTENNAS



- Different antenna sizes with on antenna matching
- Matching works for all RF modules
- 30 cm wisted wire cable for connecting the antenna to RF Modules

20x10 mm



20x20 mm

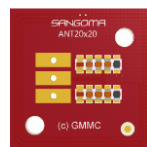

40x40 mm



72x48 mm







- **HOST INTERFACE OPTIONS**

- WIFI
- BLUETOOTH LOW ENERGY
- CAN
- RS485

- **MICROCONTROLLER**

- LPC11C24 (FEATURING C

- **RF FRONTEND**

- PN5180

- **NFC CONTROLLER**

- PN7150

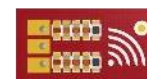

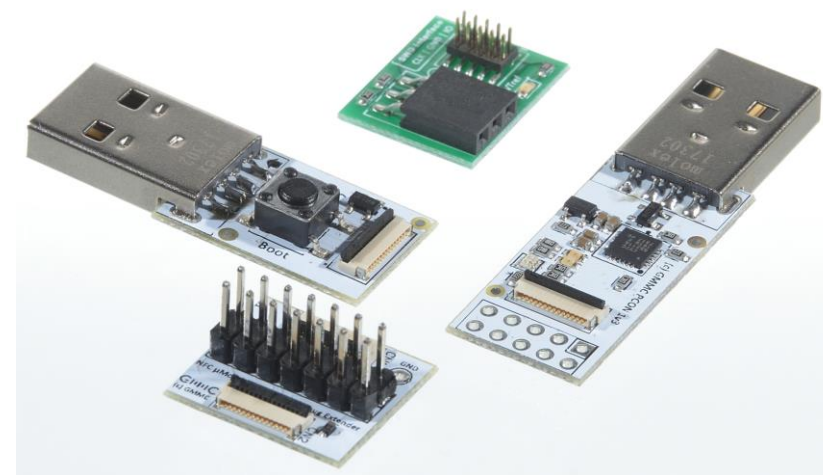
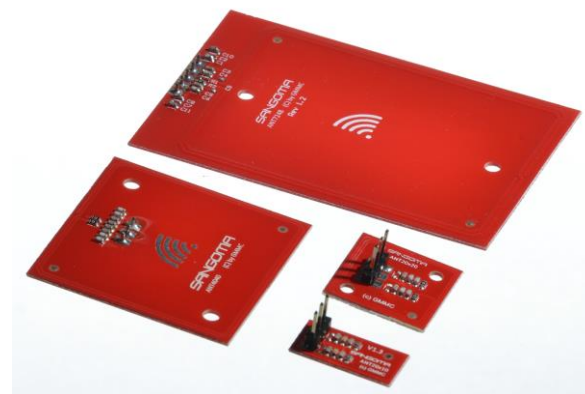
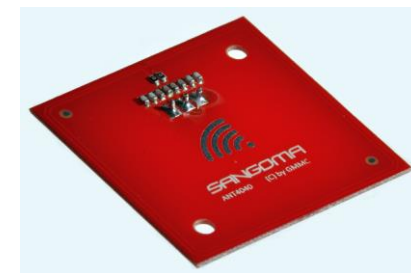

# NFC KIT PACKAGE INLAY

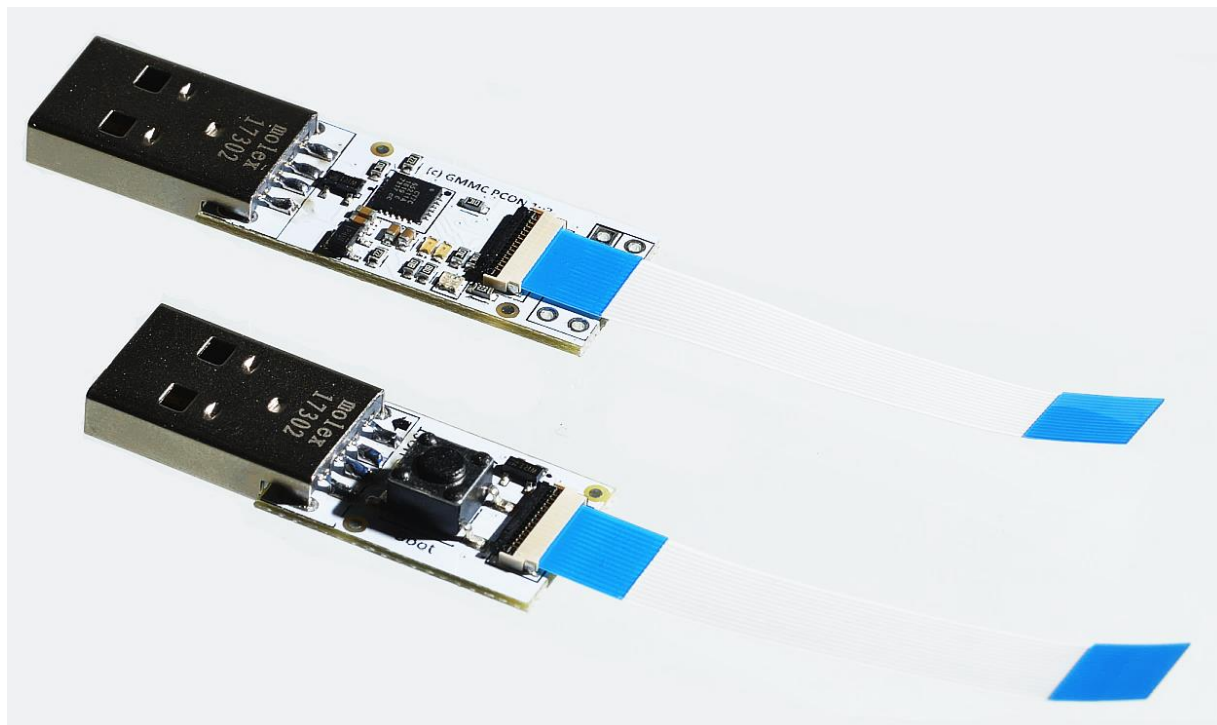

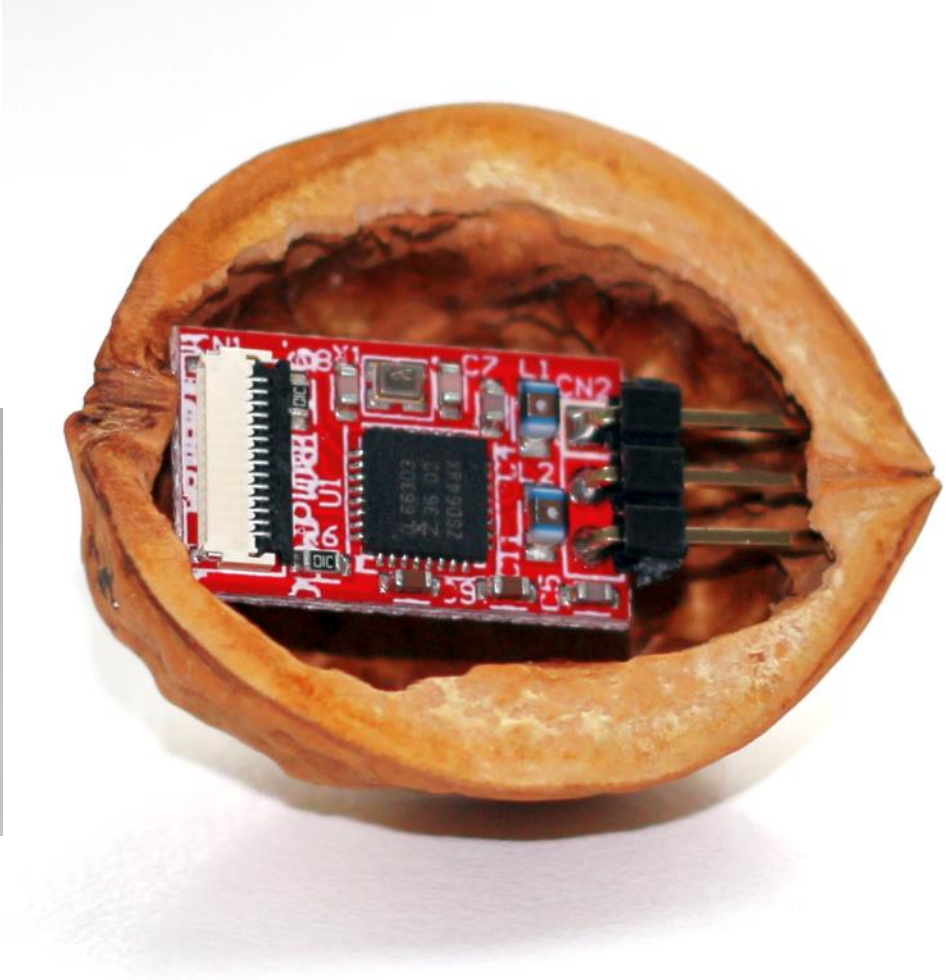
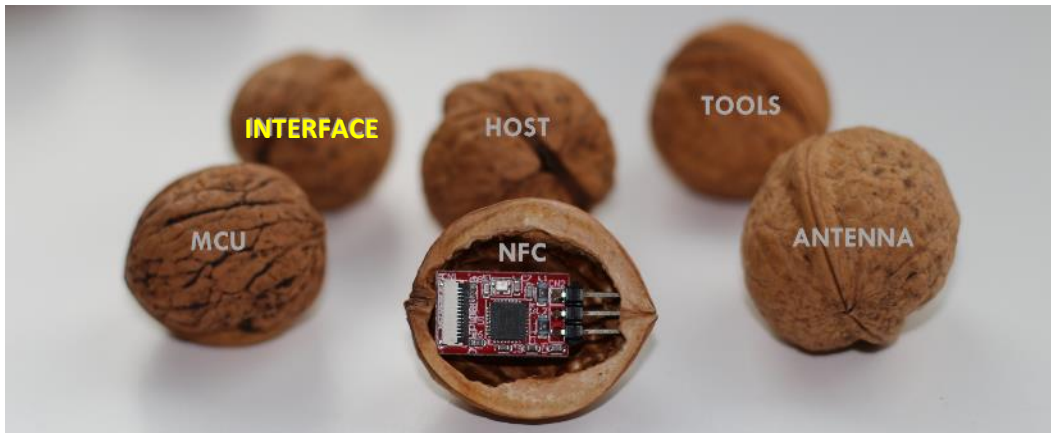

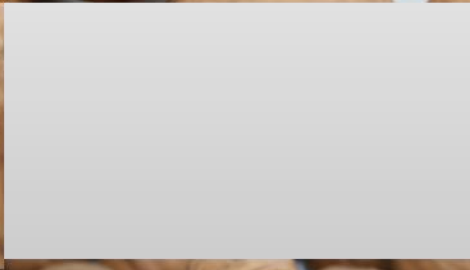
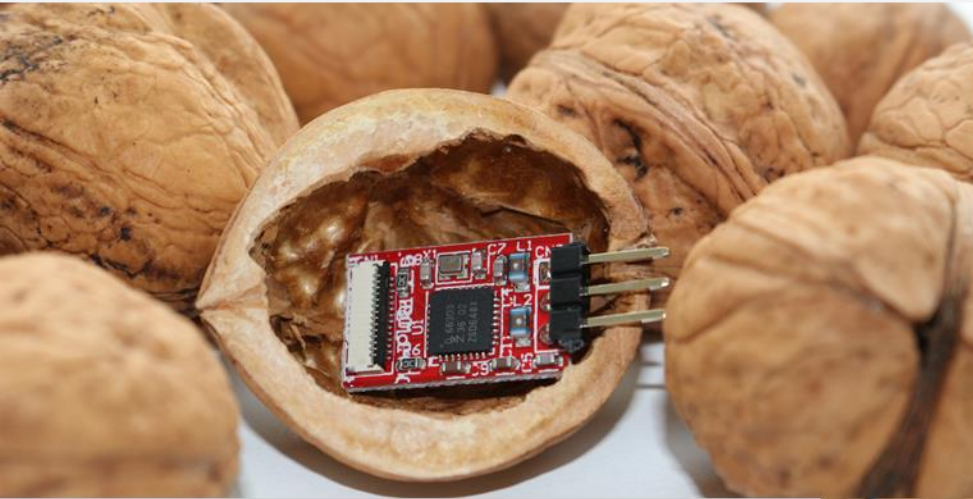
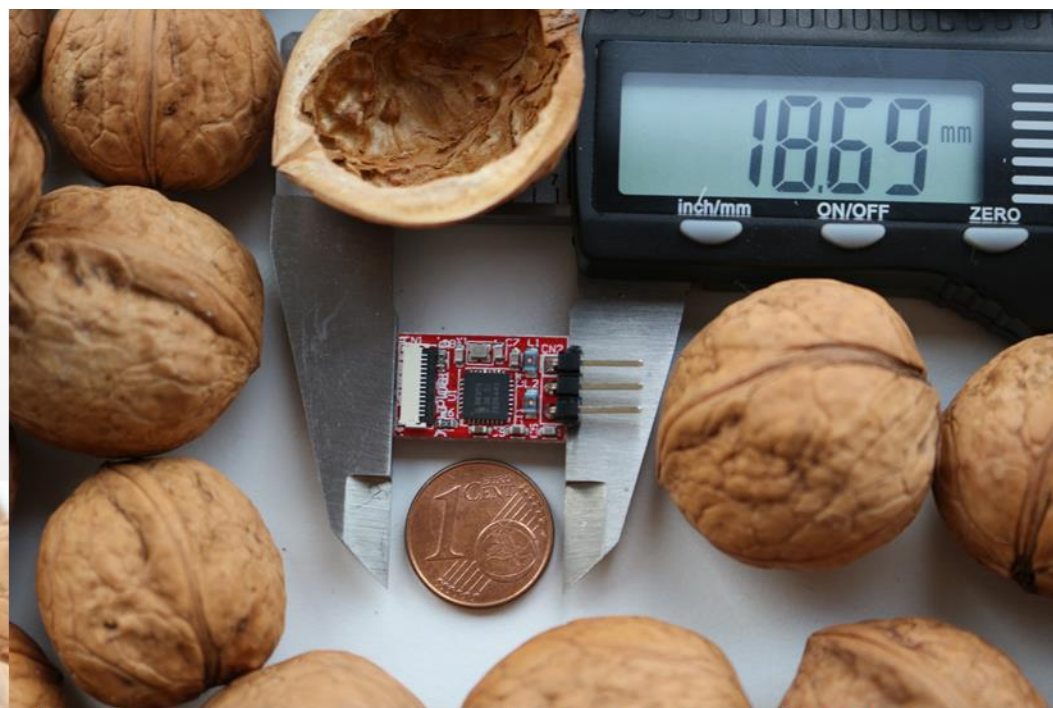
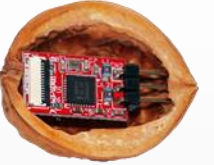

# MCU MODULE OPTIONS



**GEMIC**  
we deliver for your success

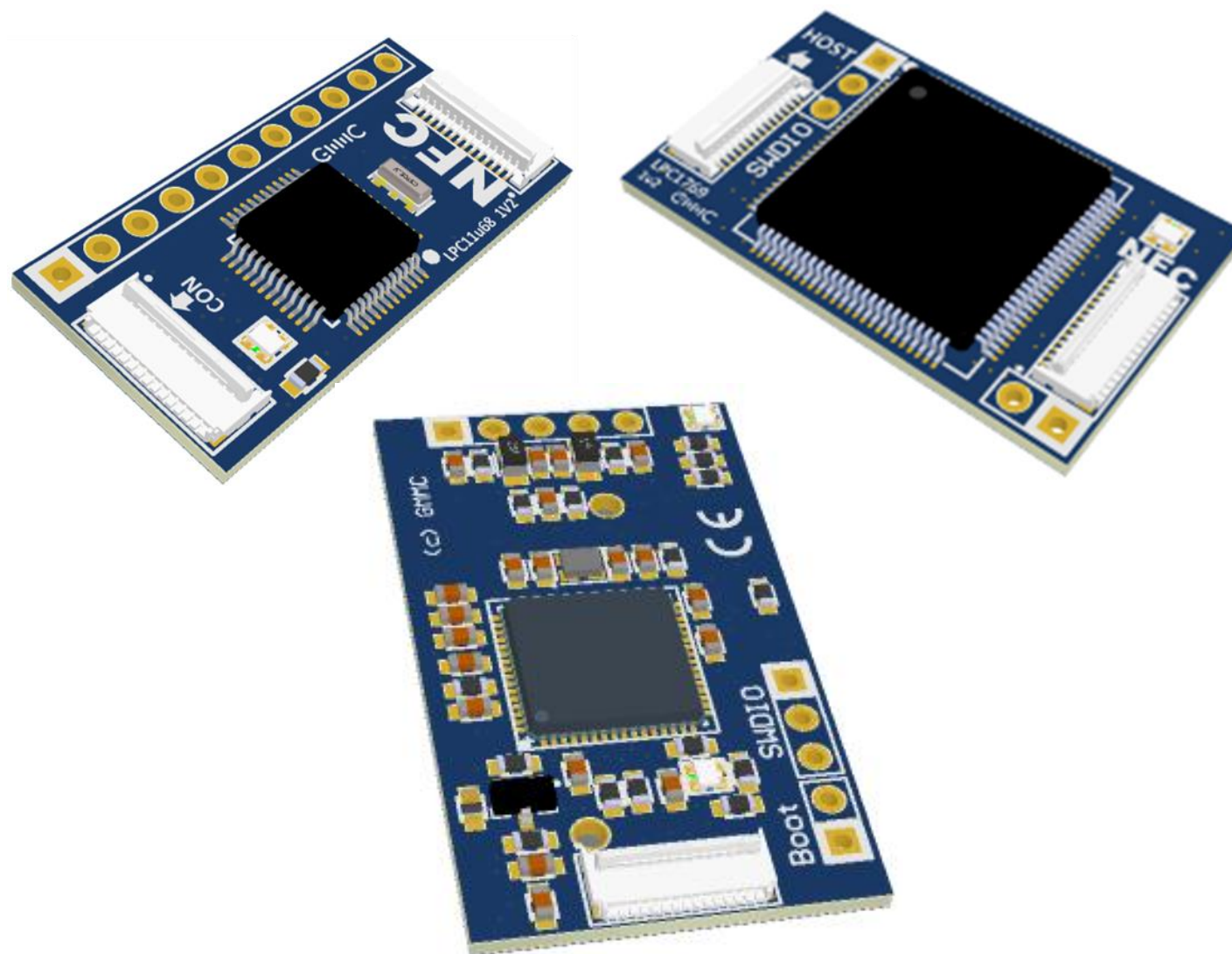

\* Not supported by all MCUs

# HOST INTERFACE MODULE OPTIONS



**GIMIC**  
we deliver for your success

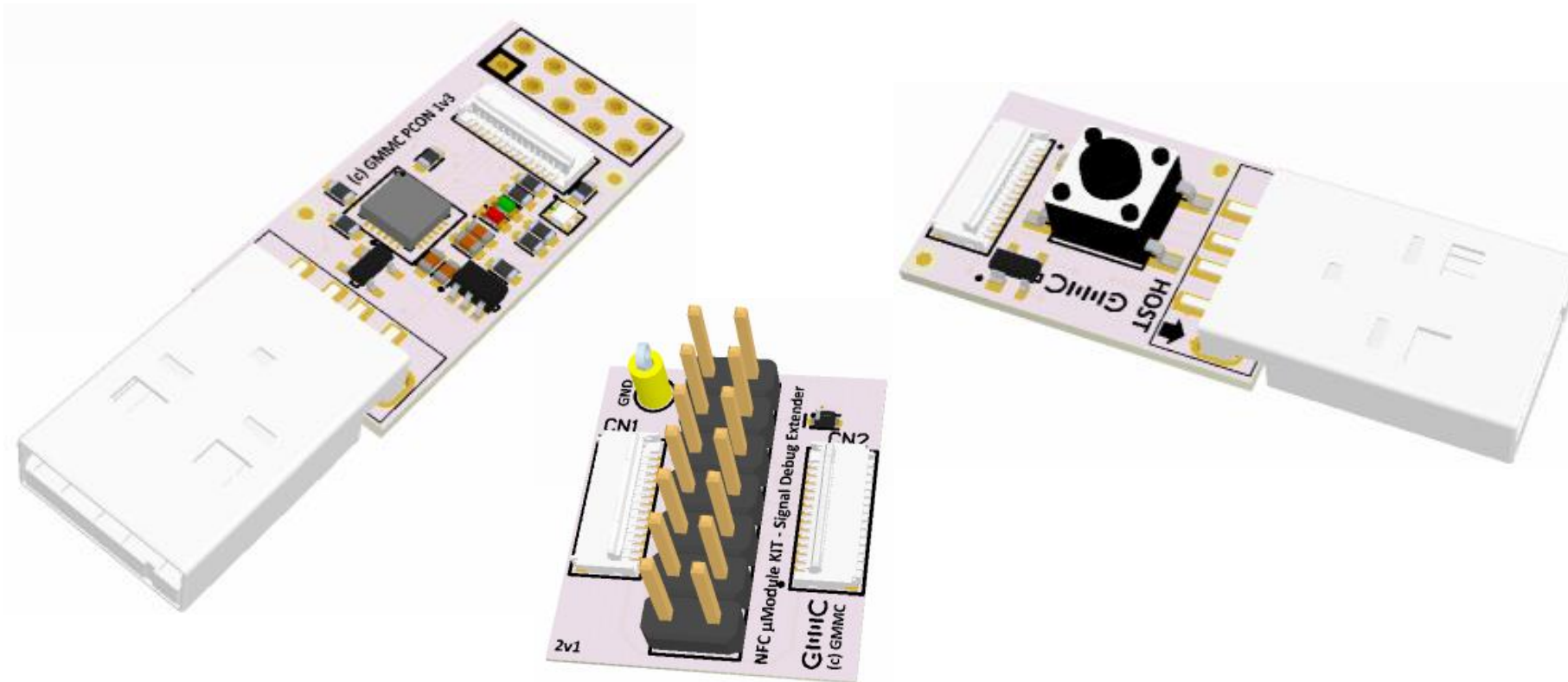

\* Not supported by all MCUs

Host ↔ Modules

1

2

3

+5V  
GND  
MOSI\_SDA\_xCTS  
SCLK\_TxD  
MISO\_SCL\_xRTS  
xSEL  
MOSI\_SDA\_xCTS  
MISO\_SCL\_xRTS  
RxD  
SCLK /TxD  
AUX1 next  
AUX2 next

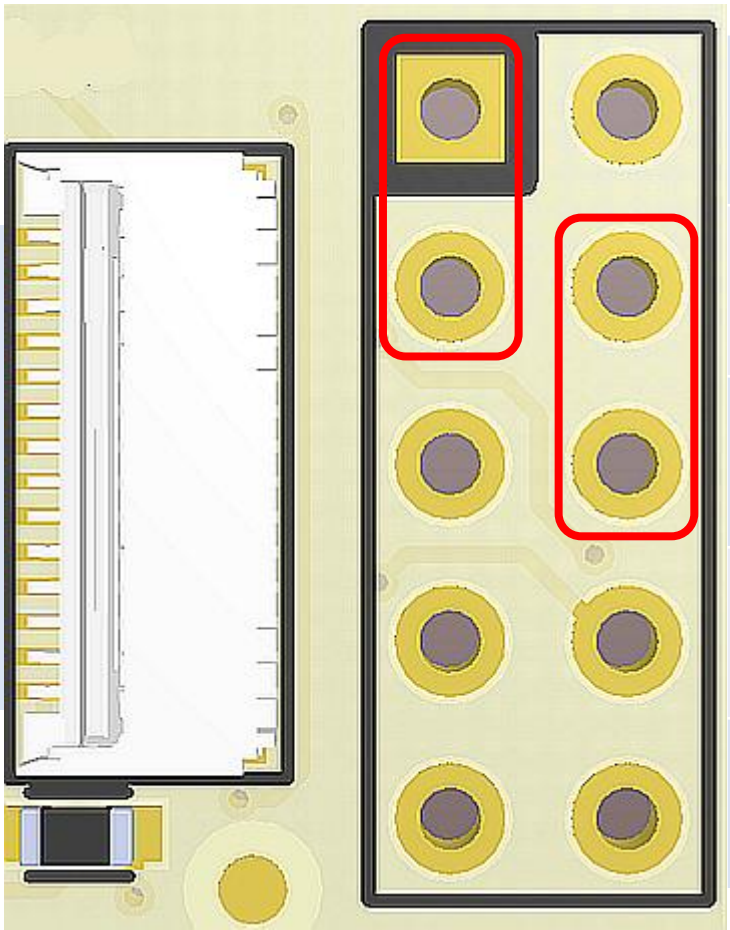

GND	RxD
+5V	SCLK /TxD
AUX1 next	MOSI_SDA_xCTS
AUX2_next	MISO_SCL_xRTS
GND	xSEL



Host ↔ Modules

1

2

3

+5V  
GND  
MOSI\_SDA\_xCTS  
SCLK\_TxD  
MISO\_SCL\_xRTS  
xSEL  
MOSI\_SDA\_xCTS  
MISO\_SCL\_xRTS  
RxD  
SCKL /TxD  
AUX1 next  
AUX2 next

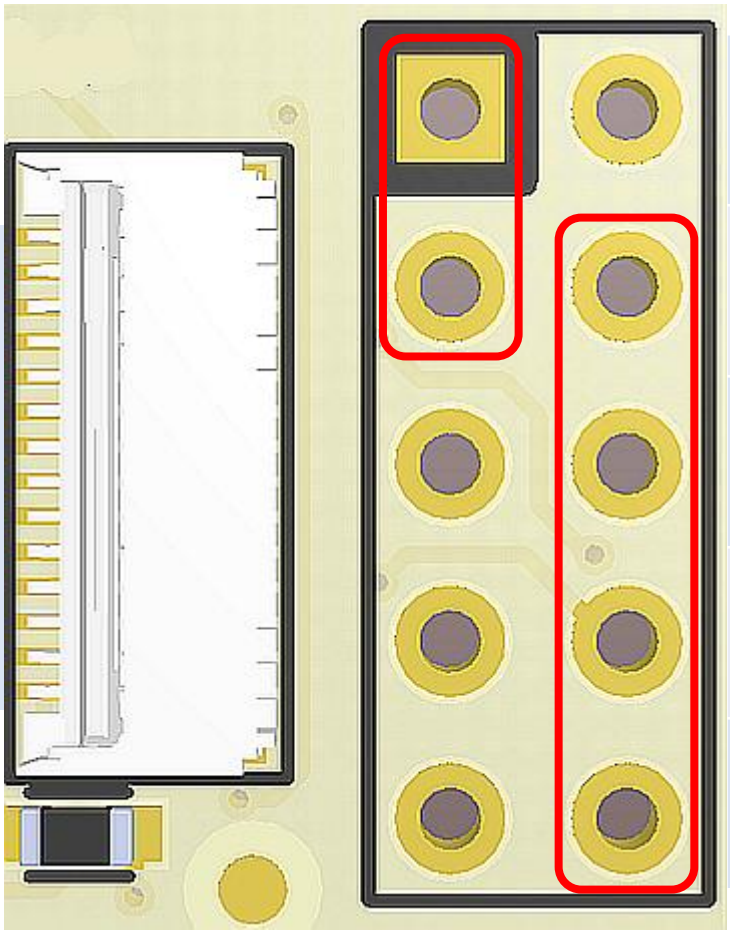

GND	RxD
+5V	SCKL /TxD
AUX1 next	MOSI_SDA_xCTS
AUX2_next	MISO_SCL_xRTS
GND	xSEL

**Host**  **Modules**

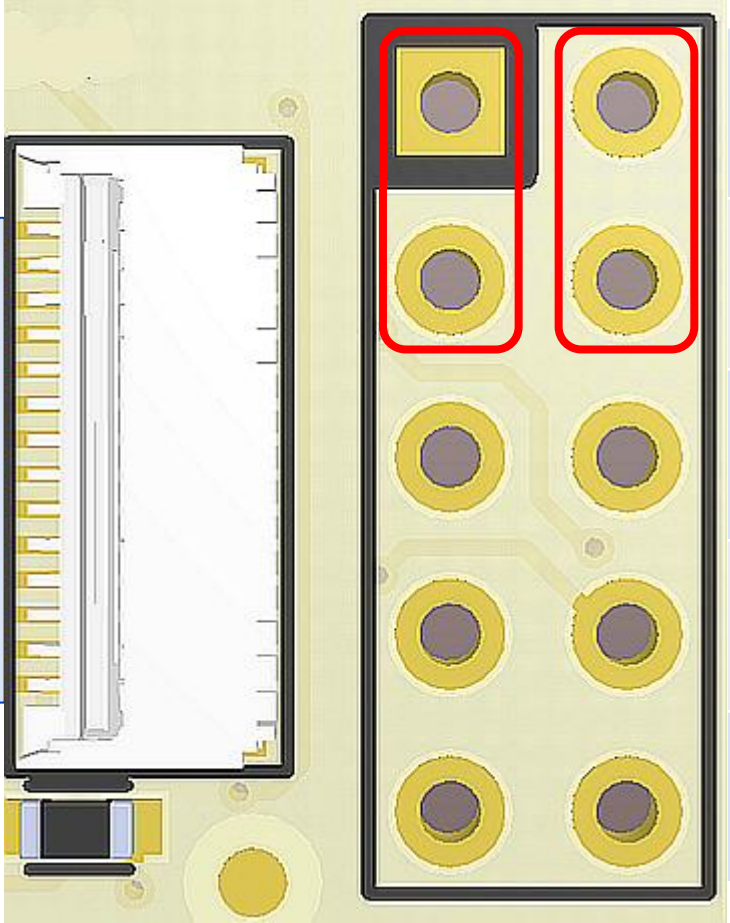

+5V  
GND  
MOSI\_SDA\_xCTS  
SCLK\_TxD  
MISO\_SCL\_xRTS  
xSEL  
MOSI\_SDA\_xCTS  
MISO\_SCL\_xRTS  
RxD  
SCLK /TxD  
AUX1 next  
AUX2 next

GND	RxD
+5V	SCKL /TxD
AUX1 next	MOSI_SDA_xC TS
AUX2_next	MISO_SCL_xR TS
GND	xSEL

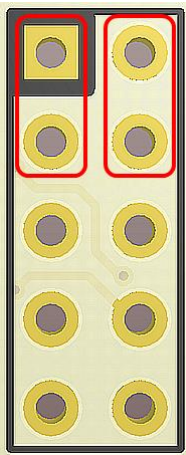

GND	RxD
+5V	SCKL /TxD
AUX1 next	MOSI_SDA_xC TS
AUX2_next	MISO_SCL_xR TS
GND	xSEL

**Host**  **Modules**

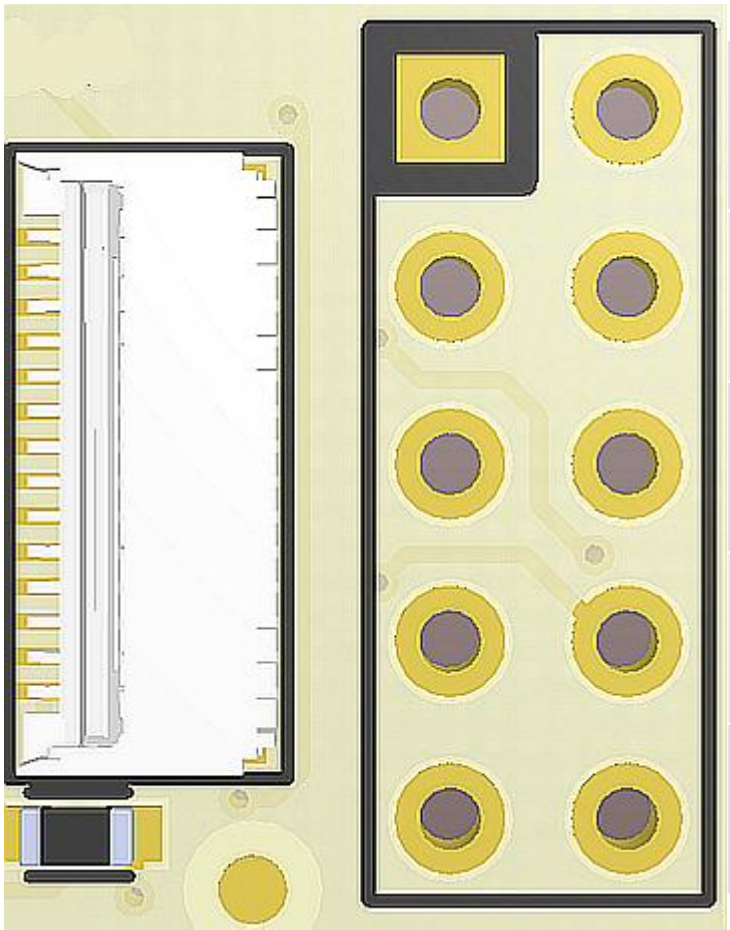

GND	RxD
+5V	SCKL /TxD
AUX1_next	MOSI_SDA_xC TS
AUX2_next	MISO_SCL_xR TS
GND	xSEL

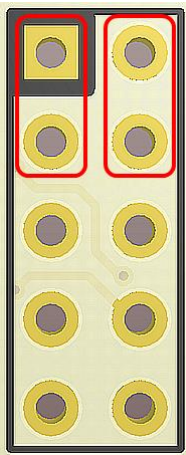

GND	RxD
+5V	SCKL /TxD
AUX1_next	MOSI_SDA_xC TS
AUX2_next	MISO_SCL_xR TS
GND	xSEL

# Module



# Module

- GND
- +5V
- MOSI\_SDA\_xCTS
- SCLK\_TxD
- MISO\_SCL\_xRTS
- xSEL
- MOSI\_SDA\_xCTS
- MISO\_SCL\_xRTS
- RxD
- SCKL /TxD
- AUX1 next
- AUX2 next



- GND
- +5V
- MOSI\_SDA\_xCTS
- SCLK\_TxD
- MISO\_SCL\_xRTS
- xSEL
- MOSI\_SDA\_xCTS
- MISO\_SCL\_xRTS
- RxD
- SCKL /TxD
- AUX1 next
- AUX2 next

